



Original papers

Web-based monitoring system using Wireless Sensor Networks for traditional vineyards and grape drying buildings



Navab Karimi^{a,*}, Akbar Arabhosseini^{a,*}, Mortaza Karimi^b, Mohammad Hossein Kianmehr^a

^a Department of Agro-technology, College of Abouraihan, University of Tehran, Tehran, 3391653755, Iran

^b Department of Computer Science, Faculty of Engineering, Islamic Azad University Tabriz Branch, Tabriz, Iran

ARTICLE INFO

Keywords:

Precision Viticulture
WSN
Gateway
Mote
Data aggregation and integration
Raisin
South Azerbaijan

ABSTRACT

The quality of grapes and the drying process has a momentous impact on the quality of the final products (raisins). South Azerbaijan is the most important region for grape growing and raisin producing. However, the majority of the vineyards in the region are traditional, and the drying process is carried out in conventional structures that are not convenient. To increase the quality and productivity, it is necessary to modernize agricultural practices with reasonable cost suitable and affordable to traditional farming and farmers. To do this, the harsh environments and severe climate conditions of the vineyards and the drying buildings should be observed periodically to collect data. Wireless Sensor Networks are a key technology that can provide precise information, can update information, and can be a valuable resource to farmers to determine appropriate management practices. Using this technology, farmers can make real-time decisions such as scheduling irrigation periods, preventing diseases, choosing the right time for harvesting and so on. In this project, a Wireless Sensor Network system was designed and developed for remote real-time monitoring and collection of micrometeorological parameter data in three distant vineyards. The system was also used for monitoring the SO₂ gas fumigation process and atmospheric parameters inside the drying structure. The system consists of a gateway and a series of peripheral wireless motes placed in the vineyards and inside the drying structure, which are equipped with agrometeorological sensors for environmental monitoring and for storing and transmitting data to the gateway. The gateway collects agrometeorological data and utilizes a wireless technology for data transmission and for communication between the motes and the central server (webpage). In addition, an on-line (real-time) warning system was embedded in the gateway to send alarm signals via SMS (Short Message Service). The devices were tested for software configuration functionality, hardware operation and data acquisition, energy consumption, and connectivity. Field experiment results demonstrated that the system represents a complete monitoring system, which provides efficient performance for developing information systems in precision viticulture.

1. Introduction

According to the FAOSAT, Iran was the ninth largest grape producer in the world in 2012 (2150000 MT). Additionally, in 2014 grape growing ranked second among horticultural products grown in Iran. The Azerbaijan provinces (South Azerbaijan) are the most important regions for grape growing in Iran, wherein more than 90% of the grape vineyards in these regions are traditional ones. Because of the cold weather and the environment of the region, the traditional vineyards are mainly in the form of large furrows. These specific furrows are called “Qana” in local Azerbaijani Turkish language and are a form of triangular prisms with a long base (approximately 25×2^2) two meters in height with a one-meter interval between every Qana (Fig. 1). Obviously, this particular kind of vineyard is not as productive as trellis

ones, but they are more appropriate to the harsh environmental and climatic conditions of the region (extremely cold winters and extremely hot summers with -20 to 40 °C records). Additionally, the conversion of a traditional vineyard to a trellis one is costly and the majority of farmers cannot afford it, and so updates would require a nationally invested project. Instead, farmers could focus on utilizing suitable modern technologies to grow, tend, and monitor their vineyards to enhance efficiency and productivity.

Additionally, Iran is one of the largest raisin exporters in the world, ranking third (after Turkey and the USA) in the world and accounting for 27% of the world's raisin exports. Compared to the other agricultural activities in the region, raisin producing has become of paramount importance for its economic values and for the size of the population involved in this kind of husbandry and commerce.

* Corresponding authors.

E-mail addresses: navab.karimi2016@gmail.com (N. Karimi), ahosseini@ut.ac.ir (A. Arabhosseini).



Fig. 1. The traditional vineyard (Qanas).



Fig. 2. Drying structure.

Traditionally, raisins are produced naturally by sun-drying and hanging the grape bunches outdoor inside a structure (Karimi, 2015), as shown in Fig. 2. Drying the grapes in shade (inside the building) can preserve their natural flavor and color. First, the grapes are pretreated by immersion in 2% K_2CO_3 solution for ruining the natural wax coating and subsequently for increasing the drying speed (Karimi et al., 2011). The grapes are also fumigated with SO_2 gas to control postharvest gray mold rot (*Botrytis*) and other decay-causing fungi, to preserve the golden color of the raisins, to prevent the enzymatic browning, and to facilitate the drying process (Franck et al., 2005; Karimi et al., 2015; Karimi et al., 2017). According to the Codex standards of golden bleached raisins, the maximum limit applicable for sulfur dioxide is 1500 ppm ($62,400 \mu\text{mol m}^{-3}$). Since excessive sulfur dioxide fumigation is extremely dangerous to human health, the process should be closely monitored and controlled. Furthermore, as the grapes are dried in the shade, the drying process is sensitive and the drying grapes (raisins) can be spoiled and molded by excessive humidity. Hence, the humidity and temperature of the building should be monitored.

Additionally, pest and nuisance birds, insects, and animals can damage and depredate grape berries in vineyards, which can demolish the quality of grapes and raisins. By monitoring damage patterns and depredating species, it is possible to reduce damage or lower the cost of

control by concentrating control methods in areas and seasons when damage is most severe.

Precision Agriculture (PA) is one of the most modern and strategic farming systems that integrates information technology with management to increase long-term, site-specific, and whole-farm production efficiency and productivity. Precision Viticulture (PV) as a specific area of PA in vineyards being used to improve productivity and quality. Grape quality and yield depend on agricultural practices, climate and soil characteristics, pests, and environmental diseases. Accordingly, using these variables, PV can provide a management strategy to enhance grape and raisin quality. Generally, PV can simultaneously improve the yield and quality of grapes and their by-products. PV practices are performed based on acquiring, transmitting, and processing agglomerative data coming from a large-scale, heterogeneous sensor network. In recent years, Wireless Sensor Network (WSN) technologies have been used efficiently to provide remote and real-time monitoring of high-quality production and processing systems. Therefore, WSNs can offer a more reliable and safe measuring process for grape and raisin production.

By monitoring environmental conditions through ubiquitous devices called sensor nodes (or motes), a WSN connects the physical and computational world. These networks include a number of motes and

one or more base stations. Usually, a base station with high processing and storing capacities is connected to many autonomous, cooperating, battery-powered, small-sized motes through wireless links and a gateway with the capability of gathering data from the motes. The motes integrate different sensors, from simple ones such as temperature, light, and humidity, to sophisticated ones including Global Positioning Systems, images, acoustic data, micro-radars, and so forth. In this manner, it is possible to monitor a wide range of environments to obtain precise online and real-time knowledge from the field.

2. Reasons and objectives of the project

2.1. Vineyard

The quality of grapes is closely related to the quality of wine, raisin, grape syrup, vinegar, and other by-products. Therefore, a scientific understanding of viticulture and long-term monitoring of cultivation environment are required for smart viticulture management and, simultaneously, for increasing the quality of the by-products. In an attempt to monitor the cultivation environment, it is necessary to collect data at multiple locations in the vineyard for convenient cultivation management since field conditions such as soil moisture may vary even within the same vineyard (Togami et al., 2011). Furthermore, by monitoring the vineyard, it is possible to estimate, assess and understand the changes that occur in grape growing stages in order to determine irrigation, fertilizer, pesticide, and insecticide requirements, growth and ripening phases, and optimum points of harvesting as accurately as possible—in other words, to adequately predict various stages in grape production. For achieving these goals, it is necessary to collect as much information as possible on the water, soil, plants, and environment. PA is an important means for determining vineyard requirements and predicting growth stages of grapes by utilizing numerous technologies and infrastructures including data instrumentation and gathering systems, Geographic Information Systems (GIS), Global Positioning Systems (GPS), microelectronics, wireless technologies and so forth (López Riquelmea et al., 2009).

There are many factors that affect the quality of grapes. Environmental variables such as temperature, solar irradiation, wind and moisture are the most important factors affecting grapevine phenology. Among them, temperature is the most important factor in vineyards. Other parameters should also be considered such as atmospheric humidity, soil humidity, and soil pH (Winkler, 1963). In general, environmental parameters can be detailed as follows.

Temperature: One of the meteorological factors that can cause various damages to the vineyard including physiological damage or disorder, effects on the degree of maturity of the grape berries, frost/freeze damage resulting from low temperatures, fungi and diseases resulting from warm weather such as black rot, etc. The optimum temperature for fungal development during the growing season is 10–25 °C. The loss resulting from disease ranges from 5 to 80% depending on the amount of disease in the vineyard, weather, and cultivar susceptibility (Šrobárová and Kakalikova, 2007).

Humidity: An atmospheric parameter (present due to rain, dew, fog or irrigation) that is a major factor in fungal growth. Fungi caused by wet and dry weather include powdery mildew, downy mildew, and bunch rot. Additionally, excessive humidity can beget a dense canopy that will not only shade the fruits but also create a microclimate within the vineyard encouraging the spread of diseases. Furthermore, by measuring the environmental (and soil), humidity it is feasible to adjust the irrigation schedules.

Soil Moisture: Water content or soil moisture is a result of a balance between water uptake (rainfall, precipitation, groundwater and irrigation) and water loss (seepage, evapotranspiration and drainage). Water stress can occur due to a lower moisture content in the soil. Furthermore, the lack of moisture during all seasons is responsible for slow development, low production, high sugar content, and a lack of

acidity in wines. On the other hand, excessive moisture adversely affects the growth, productivity, and quality of grapes, and increases susceptibility to winter injury and disease.

Soil pH: Improving the availability of mineral nutrients is one of the objectives in managing vineyard nutrient demand. Soil pH is a measure of soil acidity or alkalinity, which has a dramatic effect on the availability of several essential nutrients for grape growth. Soil pH levels that are too high or too low lead to a deficiency in many nutrients, a decline in microbial activity, a decrease in crop yield, and a deterioration of soil health. Low soil pH (pH 5.0 or lower) affects nutrient availability and root and shoot growth. Decreasing the soil pH from 5 to 3.5 results in increasing aluminum solubility so that the free and exchangeable aluminum ions affect nutrient availability and root growth. Additionally, a low pH prevents nitrogen cycling. High free aluminum precipitates phosphorus out of the soil solution and subsequently makes it unavailable to the plant. Exchangeable aluminum displaces calcium and magnesium, consequently decreasing their availability. Root growth is affected by aluminum toxicity, wherein it inhibits cell division in the root apical meristem. On the other hand, high pH soils present a different set of nutritional circumstances for grapevine roots. When soil pH increases from 5 to 8, aluminum insolubility removes it from the playing field. Accordingly, some of the phosphorus problems are obviated and the availability of calcium and magnesium is increased, but iron simultaneously precipitates out of the soil solution, limiting its availability.

It is necessary to occasionally conduct soil tests to determine whether the soil pH has changed over time. Particularly, soils gradually acidify over time due to the removal of cations such as calcium, potassium, or magnesium either by leaching or uptake by plants, acid rain, or the reaction of certain nitrogen fertilizers in the soil (e.g., urea and ammonium nitrate). There are many other factors that can result in changing soil pH such as irrigation method, water quality, temperature, land use and management, the addition of nitrogen and sulfur fertilizers, etc. In warm, humid environments, soil pH decreases over time in a process called soil acidification due to leaching from high amounts of rainfall. In dry climates, however, soil weathering and leaching are less intense and pH can be neutral or alkaline. Hence, in order to prevent certain nutrient deficiencies, the soil pH should be approximately 5.5–6.5. Accordingly, the vines will not be debilitated and vulnerable to pest and disease attacks.

Additionally, every year, the vines and grapes experience sequential growth cycles and phases so that every phase and stage has its own characteristics including the following:

- (1) Dormancy to Sprouting: In late January to early March the vines are awakened and pass the dormancy phase. During this change, the vines are pruned and begin to leak a colorless liquid, sometimes reddish; this is called the vine weeping phase. This phase usually lasts approximately three to four weeks.
- (2) Sprouting to Blooming: In April, when temperatures reach 10 °C, the sprouting phase begins. Buds swell and break, and initial small leaves appear. During this phase and during the subsequent blooming (flowering) phase, the vine is vulnerable to frost damage. During sprouting and flowering stages, water demand is low, so there are rarely water shortages. However, adequate moisture (water content) is required to promote bud break, root growth, shoot growth, and nutrient uptake. Water availability during the blooming stage is critical for continuous nutrient uptake, increasing fruitfulness, and potentially increasing berry size.
- (3) Blooming to Veraison: In late May, the blooming (flowering) phase occurs. The flowering consists of the flowers opening, resulting in fertilization. Lack of heat, excessive moisture, or lack of vigor of the plant can cause the flower to be incorrectly fecundated, and the grape bunches can have few berries (flowering shift). Adequate water during flowering can prevent a reduction in the potential harvest as a result of the reduced number of bunches. In July, the

physiological maturity of the vine commences. The berries are still far from being mature grapes, but they have already started the ripening process. As August arrives, a phase called veraison (“Qora-Şirin” in the local spoken language) begins. In veraison, the berries’ greenish color changes to yellowish for white grapes and pinkish for red grape varieties. During the veraison phase, the acidity of the grapes decreases and the sugar amount is increased; sour berries become sugary, and their skin gradually softens. During the following growing seasons, the clusters are formed (after blooming), wherein adequate water is demanded. From fruit set to veraison, water is required for cell division, which determines berry size. Throughout this stage, the shoots, roots, and canopy are still growing, and the water demand is at its maximum level. Evapotranspiration values are also highest during this period and the volumes of replacing water can be high. This is the most crucial period to apply water.

- (4) **Veraison to Harvest:** During this stage, the maturation phase occurs. After veraison, a limited amount of water is preferable. Water is still required by the berries for cell expansion, but excessive moisture may promote shoot growth, hindering the vine’s acclimation process. Therefore, in order to achieve a balance between quality and productivity during the maturation phase, the amount of water has to be sufficient, but not too much. More importantly, during early September (before the harvest), the amount of sunlight and humidity between leaves and the soil surface (where the vines are lying down on the face of the Qana triangular prism) have the most striking effect on maturation and grape bunch plagues. Excessive sunlight can frazzle, scorch, and sear the grape berries. On the other hand, the humidity of this spatial zone beneath the leaves can result in plague and fungal diseases of the grape bunches, especially botrytis bunch rot (gray mold) and other fungal diseases such as black rot, sour rot, and downy mildew. Hence, in order to avoid such problems, the number of leaves has to be controlled by manually thinning the leaves or leaving them to remain. Near to harvest time from mid-September till mid-October, evapotranspiration values are much lower than earlier in the season, and root and shoot growth have essentially ceased. Hence, depending on the terrain characteristics (dry or wet), the grapes are ready to be harvested. It is extremely crucial to prioritize the harvesting operation according to the meteorological and geographical conditions of the vineyard.

Importantly, uniform maturity is a factor that affects the quality of the raisin, and other by-products. The presence of hot or cold spots can result in variations in the degree of the fruit maturity. Moreover, the changes in the plant humidity throughout the entire growing season has a direct impact on the yield and grape quality. In case of water shortages and hot weather, the type of terrain is the most important factor that affects the vine moisture and grape maturity.

The daily temperature profile is one of the most important environmental factors for grape quality, especially during the cold months and the month during the ripening phase. Real-time atmospheric temperature monitoring combined with historical data prediction could prevent frost effects. In the case of frost/freeze protection, monitoring air temperatures should be done throughout the vineyard, which is costly in terms of capital, labor, and operating costs. Additionally, the monitoring and analysis of humidity patterns for any phenological stage can also provide an effective way to avoid some crop pathogens, such as powdery mildew. Specifically, irrigation management is essential for high-quality grape production, and therefore it is necessary to measure soil moisture. Importantly, monitoring soil pH from blooming to veraison can notably provide conducive information about applying fertilizer to the vineyard.

The WSN and PV technologies enable farmers to track the vineyard’s condition and progression. It is possible to compose an information database and use the data to support specific decisions and actions. Real-time data from a sensor network deployed in the field can be used

by experts to make decisions such as the irrigation policy, to locate the spots of vineyards exposed to excessive sunlight, or to take the desired actions at the time when fungus or grape plagues are detected. Furthermore, WSN technology has other notable benefits such as being non-intrusive (with little to no human intervention) and being available for inexpensive prices. Additionally, because of some geographical factors such as the orientation and slope of the landscape, it is possible for vineyards located at different distances to have considerably different temperatures, humidity, etc. Thus, monitoring spatial variability of the conditions affecting the grapes can be feasible by deploying the appropriate sensor network.

Lastly, WSN technology can be applied in vineyards to detect nuisance insects. In recent years, the region’s vineyards are suffering mainly from two kinds of insects, the cicada and the cricket. These insects damage grapevines primarily through their ovipositional activities such that vine growth is being affected adversely and severely. Cicadas especially have broken out, and the trees have been overwhelmed by the sheer numbers of the females laying their eggs in the shoots. Small trees have wilted and larger trees have lost small branches in some vineyards. These insects spend 17 years underground before crawling from the soil in late May and early June and immediately shedding their last immature skin to begin life as an adult. They immediately begin to sing, which they do incessantly from dawn to dusk. Their pathogenic existence and damage are concurrent with their strident singing sound (acoustic signals). By applying a WSN with its sensor nodes configured to sample audio signals and recording the sounds, it is possible to detect insects from their surrounding environment.

2.2. Drying building

2.2.1. Drying process

Generally, the processing and environmental data acquisition inside the drying buildings can be performed manually, visually, and occasionally, or it can be carried out using wired systems that are normally expensive and not flexible. Additionally, in regard to security and accessibility, these solutions are not secure or appropriate since it is necessary to hire workers to take measurements inside the fumigated and dangerously polluted environment and far inaccessible sections of the building. Uniform environmental conditions inside the building are required in order to maintain a high drying quality and, consequently, to produce raisins with higher quality. Thus, farmers must stay informed of the environmental factors and conditions inside the building such as humidity and temperature during the several weeks of the drying process. Therefore, the grape drying process inside the building can be monitored more easily and comfortably by deploying WSN technology and tools.

2.2.2. Fumigation process

As was mentioned, the fumigation process is extremely sensitive and hazardous. If the fumigated amount of SO₂ (dioxide sulfur) is low, the process will be useless and futile. On the other hand, excessive fumigation can ruin and vitiate the berries. Meanwhile, visually or manually monitoring the process is extremely dangerous to the workers’ health. Here, remote monitoring is the best solution. Consequently, by implementing WSNs the visual monitoring issue can be obviated without further ado.

3. Relevant research review

In recent decades, there have been many different investigations using and implementing WSNs in various crop production applications. In regard to precision horticulture, López Riquelmea et al. (2009) presented the topology of a deployed network using four types of nodes (Soil Mote, Environmental Mote, Water Mote and Gateway Mote) to measure various soil properties such as temperature, volumetric moisture content, and salinity. The system was successful for the

ecological monitoring of cabbage crop for the entire growing season with the required precision. Hwang et al. (2010) proposed an agricultural environment monitoring server system for monitoring information of an outdoor agricultural production environment utilizing wireless sensor network (WSN) technology. The proposed server system collected environmental and soil information outdoors through WSN-based environmental and soil sensors. Garcia-Sanchez et al. (2011), deployed WSNs in order to integrate video-surveillance and data-monitoring over distributed crops. They developed wireless node prototypes providing agriculture data monitoring, motion detection, camera sensors and long-distance data transmission. In another study, Jiang et al. (2013) reported an application of a web-based remote agro-ecological monitoring system for observing spatial distribution and dynamics of *Bactrocera dorsalis* (phytophagous insects) in fruit orchards. To achieve real-time system management and data inquiry, a remote control interface and a web-based decision support program was implemented to allow system administrators and users to remotely access the monitoring report of their farms via the internet from virtually anywhere. Srbínovska et al. (2015) carried out a research project on environmental parameter monitoring using wireless sensor networks, which was deployed in a pepper vegetable greenhouse. Their presented WSN system consisted of sensor nodes and a base station, which was used for measurement and data collection of parameters such as temperature, humidity, and illumination.

Moreover, other studies have been conducted applying WSN technologies in agricultural services such as soil water content sensing (Pan et al., 2013; Sun et al., 2014), crop disease risk evaluation (Das et al., 2009; Rossi et al., 2010), fertilization, pesticide spraying (Santos et al., 2014), crop temperature sensing (O'Shaughnessy et al., 2013), remote sensing and control of an irrigation system (Kim et al., 2008), autonomous closed-loop zone-specific irrigation (Goumopoulos et al., 2014) and valve control (Coates et al., 2013; Dobbs et al., 2014), automated irrigation management based on the water content and temperature of soil, humidity, temperature, wind speed, and irradiance (Nikolidakis et al., 2015), and frost protection and dew condensation prevention (Park and Park, 2011; Pierce and Elliott, 2008).

Specifically, for a precision viticulture (PV) application, researchers have conducted outstanding projects using WSNs. Burrell et al. (2004) presented a study on the potential use of sensor networks to aid work in vineyards. They described a variety of sensor network configurations and applications that can address different priorities of the vineyard. Beckwith et al. (2004) implemented a 65-node multi-hop WSN in a vineyard for six months. The collected information was used for addressing two important parameters of heat summation and potential frost damage in wine production. Morais et al. (2008) used a ZigBee multi-powered wireless acquisition device for remote sensing applications in PV. They designed a platform for that purpose called MPWiNodeZ, as a ZigBee™ network element that provides a mesh-type array of acquisition devices for vineyards. Shah et al. (2009) designed a PV framework in the vineyards at Nashik, Maharashtra, India. They deployed wireless sensor nodes equipped with soil moisture, ambient temperature, relative humidity, and leaf wetness sensors. Data collected by the sensors were wirelessly transferred in a multi-hop manner to a base station node (approximately 700 m away from the mote) connected with an embedded gateway for data logging and correlation. The embedded gateway base station performed elementary data aggregation and filtering algorithms and transmitted the sensory data to an agri-information server via GPRS. Additionally, Matese et al. (2009), designed a remote real-time system for monitoring and collecting micrometeorological parameters in a vineyard. The system comprised a base agro-meteorological station (Master Unit) and a series of peripheral wireless nodes (Slave Units) located in the vineyard. In this project, the Master Unit stored all of the Slave Unit data and, using a GSM/GPRS device, sent all the collected data to a remote central server. In 2011, an autonomous intelligent gateway infrastructure for in-field processing in precision viticulture was designed and installed in a vineyard. The

infrastructure, named iPAGAT (Intelligent Precision Agriculture Gateway), ran an aggregation engine that fills a local database with environmental data gathered by ZigBee WSNs and it possessed embedded communication capabilities such as Bluetooth, IEEE 802.11, GPRS (for accessing both gateway and remote data by local and remote users), and the internet, and it ran site-specific management tools using authenticated smartphones (Peres et al., 2011). Accordingly, Fernandes et al. (2013) utilized this infrastructure (iPAGAT) and introduced a framework for WSN management for PV and agriculture based on IEEE 1451 standard. The framework consisted of a ZigBee end device (sMPWiNodeZ), an IEEE 1451 WTIM (Wireless Transducer Interface Module), and an IEEE 1451 NCAP (Network Capable Application Processor) that acts as a gateway to an information service provider, and a WSN coordinator. More recently, Reiser et al. (2017) designed and utilized a small 4-wheel autonomous robot that assembled the data from nodes distributed in a vineyard in order to overcome the limited transmission range of spatially separated nodes of a wireless sensor network (WSN).

The current innovative systems and projects applying WSN technology to vineyards have their own merits for solving the multiple challenges existing in the modern vineyards. However, there are some factors that should be considered, improved, and ameliorated such as

- **Cost:** The existing research and development state for selecting and implementing the components are considerably expensive. Specifically, in the traditional and deprived regions such as South Azerbaijan (wherein the devices are imported from foreign countries), the devices are not affordable to the end-users. For applications in such regions, reducing the system cost is utterly urgent. Thus, a low-cost application design is extremely necessary for selecting and implementing sensor nodes and hardware.
- **Energy-efficiency:** In any WSN-based system, energy management is one of the most challenging issues. The amount of energy consumed by sensor nodes can be reduced by reducing the amount of communication in the network. This can be done by designing different system components and algorithms, or alternatively, by considering other potential energy harvesting solutions such as solar power, wind power, biomass, vibrations, power banks, and so on.
- **Complication:** The hardware components and designed platforms used in the proposed WSN systems are sophisticated and therefore should be simplified and easy to use. In this manner, in order to ensure ease of operation for the end-users who are typically farmers and non-technical persons, human–computer interaction issues such as accessibility and usability should be considered in designing and developing the system's architecture.
- **Traditional vineyard issues:** Unlike in developed countries, the traditional vineyards in the region are partitioned, smaller, and personalized farming lands. Additionally, the structure of the vineyards is completely different from the modernized trellis ones. Thus, a specific and suitable deployment architecture is needed.
- **Raisin quality:** Virtually all of the existing research projects are concerned with grape and wine quality only. However, the characteristics of grapes (such as sugar level, alcohol level, acidity, etc.) that are grown for wine are completely different from the grapes that are produced for raisins.

To our knowledge, there is not any research on traditional vineyards and grape drying (raisin producing) structures. The aim of this research is to integrate and equip the traditional vineyards with simple and easily used architecture, low-cost devices, and low powered components, which are more felicitous and tailored to the need of the region's farmers.

4. Materials and methods

In this section, the implementation of the proposed system is

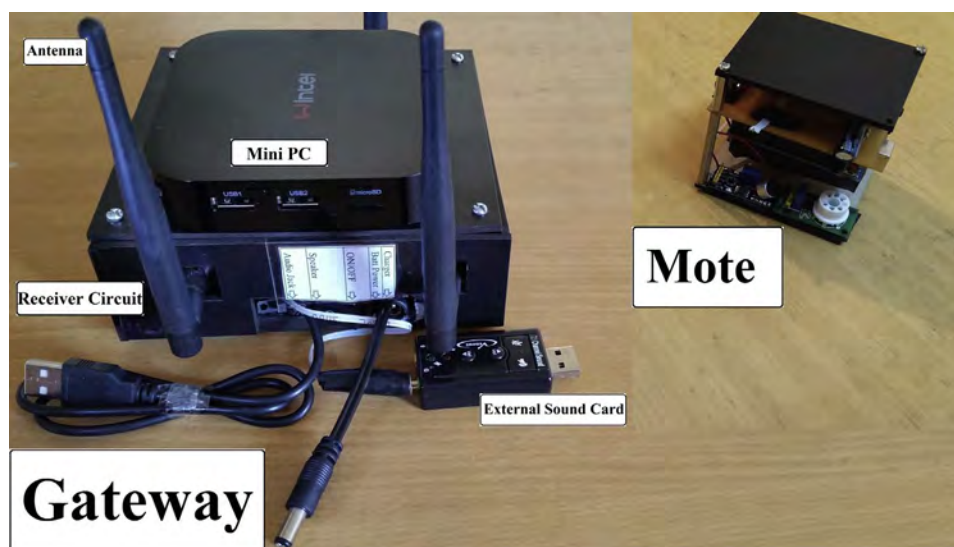

Fig. 3. Gateway and a typical sensor package (Mote).

described. First, the hardware-software design of the system, the communication protocols, and the topology of the system are presented. Finally, the energy issues and implementation details are explained.

4.1. Architecture design

The hardware architecture of the system resembles the Master/Slave configuration (Fig. 3). The Slave Unit (SU) is composed of a series of wireless motes located in the various locations of the vineyard with their sensors for monitoring meteorological and environmental parameters. The SU utilizes wireless technology to communicate and transmit the data to the Master Unit (MU). The MU is a base station, i.e., the gateway, which collects data from the entire vineyard, and then stores and processes them. Additionally, the web page designed as the management software for the transmission function is used to provide a connection between the operator and the gateway. Other software is used for designing the database and hardware programming and is detailed in the following sections.

4.1.1. Hardware architecture

4.1.1.1. End devices (Motes). Each End Device (ED), or mote consists of one or more sensor and module inputs. Motes are composed of a processor, a radio module, a power supply and one or more sensors mounted on the mote itself or connected to it (López Riquelmea et al., 2009). The gateway sends a data reading request to the end device and consequently, the end device responds with the value from the sensors. The ED consists of two interface parts: the sensor and the wireless communication interfaces. The interfaces are imbedded in Arduino Board and are included as a sensor shield and nRF24L01 module for sensing and sending the data, respectively, so that the sensor interface receives the data from the sensors and sends it to the gateway via the wireless communication interface (nRF24L01 module). Therefore, the end device’s components are Arduino boards, modules, and sensors:

Arduino Board: Arduino is an open-source project that creates microcontroller-based kits in order to build digital devices and interactive objects, whereby they sense and control physical devices. The main component of an Arduino board is an Atmel 8-, 16- or 32-bit AVR microcontroller with other synchronized components that provide programming and collaboration with other circuits. The Arduino project provides a cross-platform application written in the Java programming language, named Arduino’s integrated development environment (IDE). IDE is a programming environment in which the codes (sketches) are written, compiled and uploaded into the embedded microcontroller. The Arduino series that was used in this project was the Arduino Uno,

Nano, and Micro, which are based on the ATmega328P and ATmega32U4 microcontrollers’ board.

Modules: Various sensor modules are connected to a mote (ED) in order to acquire the data and transmit them wirelessly to the base station (gateway), where the data are stored. The modules utilized in this work include nRF24L01 module, VS1003 acoustic module, GSM module, and U-blox NEO-6M module (GPS receivers).

Sensors: To monitor and acquire real-time data from the field, multiple types of sensors were integrated into the data acquisition network such as DHT11 digital temperature and humidity sensor, TGS 813 sensor for SO₂ gas, PIR motion sensor, soil pH sensor, and EC-5 soil moisture sensor.

4.1.1.2. Gateway architecture. An Intel Atom processor with a 1.83 GHz has been used as the motherboard of the gateway (Fig. 3). This mini motherboard works with x86 architecture, wherein it supports all the software that can be installed on the real windows. Its size is 10 × 10 cm and it has 2G RAM and 32G eMMC. Other features of the device have been detailed in Table 1.

The Mini PC is connected to the peripheral motes through the receiver circuit. The receiver circuit’s components include Arduino UNO, Arduino Nano and Micro, a GSM module, an NRF24L01 receiver module, a power supply, M2596 (regulator), an external sound card, and antennas.

The gateway is the heart of the proposed system, and it runs all the management operations such as managing the received and transmitted data, optimizing the energy consumption in the motes, pooling the

Table 1
Detailed features of the coordinator motherboard.

Features	Details
CPU	Atom
Chipset	Intel atom processor z3735f (2M cache up to 1.83 GHz)
Cache Memory	2.Mb
RAM	2 G
Storage	Emmc 32G
GPU	Intel HD Graphics 311.00 MHz
Wi-Fi	Yes
Bluetooth	Yes
LAN	10/100 Mb
Video Output	HDMI
Port	4xUSB2.0
Operating system	Windows 10
Dimensions	(10 cm × 10 cm)
Power	5 V 3 A

motes, and managing the alarms. The gateway consumes a 5V–2A energy source, and it uses mains electricity. However, two rechargeable batteries are also used in the case of emergencies.

To manage the limited energy capabilities and consequently prevent the system’s shutdown, a “pooling” technique was ingrained into the gateway architecture. Pooling is one of these methods, which functions based on an on-demand approach. In the continuous approach, the motes send the data periodically according to the defined amount of time, without any management techniques. In this form of operation, the motes are working in continuous mode and, since the maximum amount of energy is consumed by the receiver and transmitter modules, the energy consumption and lifetime of the network are affected. However, the system can be designed based on on-demand measurements, as well. In this method, the gateway inspects the mote data in order to shift their sleeping mode to the active mode and actuates them to send their data to the gateway and then return to the sleeping mode. Additionally, the time of the inspection operation can be adjusted according to the different seasons and conditions. For example, inspection can be done in minute, hourly, or daily rates instead of every 250 ms. Accordingly, the energy-efficiency and performance of the system can be optimized.

In general, the gateway functions as the sink node of the WSN system, whereby the gateway’s Mini PC is connected to the sink motes (via the receiver circuit) and monitoring center (Fig. 3). The gateway also executes other duties such as data aggregation, real-time warning system, web access with Ethernet cable and Wi-Fi, network management, and environmental data resource.

4.1.2. Software design

In this section, all the software specifications that were used in this project are described. In Fig. 4, the flowchart of the end device and the gateway function is presented. Furthermore, the functional description of the software architecture of the gateway and the motes (end devices) is presented in Fig. 5.

Software specifications include the following:

(a) **Microcontroller:** The Arduino IDE was used as a code editor and code burner. By connecting to the Arduino hardware, the IDE (Integrated Development Environment – or Arduino Software) makes it feasible to upload programs and communicate with them.

(b) **Web-Server:** A simple HTML/AJAX running on the gateway was used in this work. Using AJAX, web pages can be updated asynchronously by exchanging data with a web server behind the scenes. In other words, updating parts of a web page can be executed without

reloading the entire page. The XAMPP application was used for the web server, which is comprised chiefly of the Apache HTTP Server, MySQL database, and interoperates for scripts written in the PHP programming language.

(c) **On-line warning system:** The warning system is a software that is installed within the overall system. The online warning system designed for the project is a system based on a webpage, which works according to the defined threshold of parameters such as temperature, humidity, soil pH, soil moisture, motion, and gas concentration level. The codes were written in Brackets IDE with HTML and JavaScript. In this system, an alarm is sent to the operator via the webpage. Accordingly, the operator (farmer or manager) will manually or automatically take appropriate actions in order to obviate the problems. Additionally, the system stores the alarms in the database, and by using the designated lights on the webpage, warns the operator. Furthermore, the proposed system is able to send these alarms to the operator via SMS. To perform this kind of communication and connectivity, a SIM900A module was used on the gateway board. SIM900A module is a simple Arduino GSM module for sending SMS. The module supports communication in a 900 MHz band. Programming of this module, like other modules such as nRF24L01, is performed in Arduino IDE. Hence, the online warning system alarms the operator via SMS and the webpage. The system generates alarm signals in order to warn of probable frost, likely disease, irrigation schedule, pH abnormality, an anomaly in fumigation and drying processes, and motion changes.

The online warning system checks the data from the gateway in order to compare the sensor readings stored in the database with the limits defined by the minimum and maximum amounts of parameters for every measured condition such as frost, excessive fumigation and so forth. While the evaluated parameters are exceeded or declined, a signal (alarm) is sent by the system to the operator via SMS and the webpage. For instance, if the air humidity reaches 95% and air temperature decreases to 3 °C, an automatic alarm is generated and sent via SMS and webpage. The operating rule codes are uploaded to the gateway, which contains the defined threshold values of the parameters that are used by the online warning system in order to send the alarms. For example, the “frost Prediction” alarm can be scripted as the following schematic algorithm (rule):

```

If (Day > 80 && Day < 120)
{
  if (Temp < 3 && Hum > 95)
  {

```

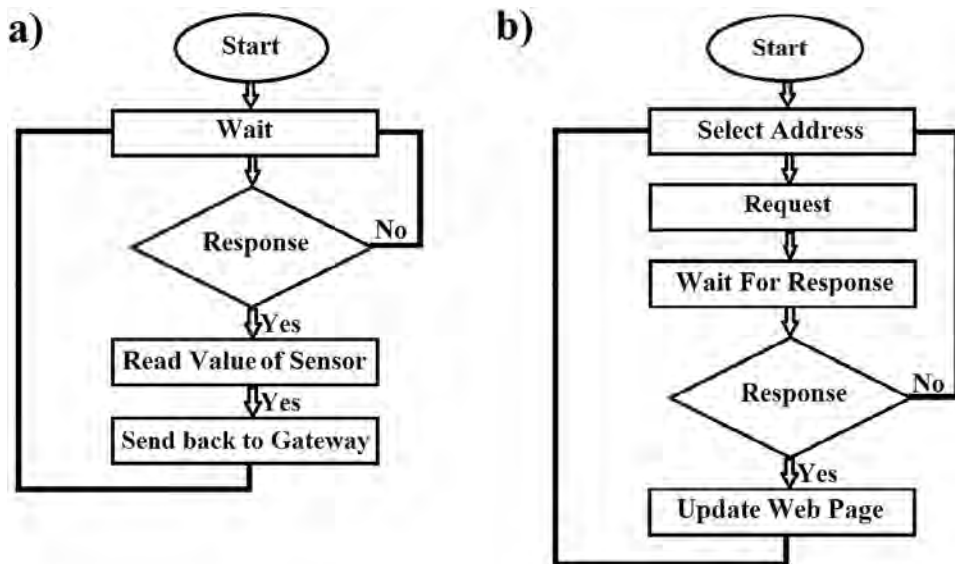

Fig. 4. The function flowcharts of (a) End Device (Mote) and (b) Gateway.

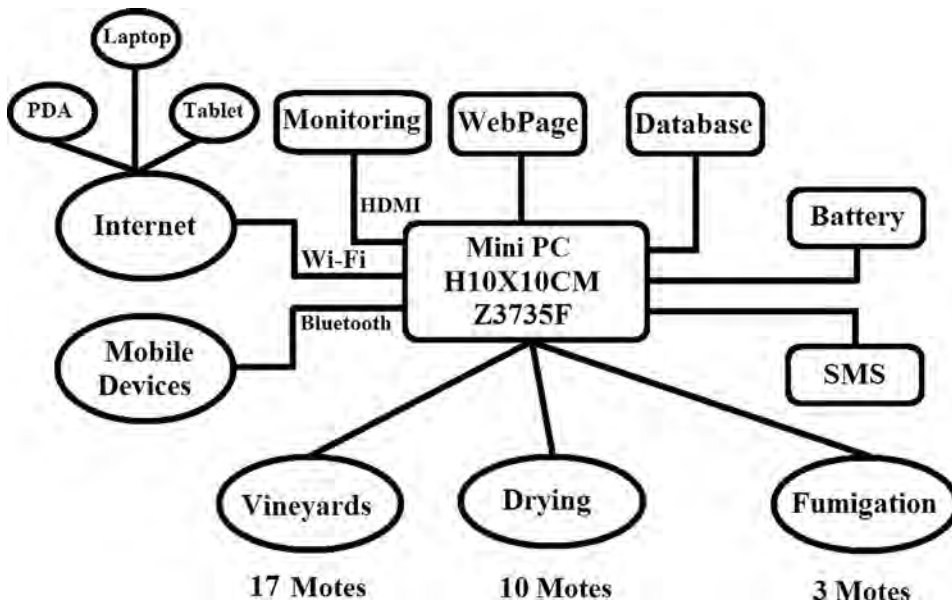

Fig. 5. The functional description of the gateway's software architecture and the peripheral nodes.

```

char number [ ] = "0914*****";
char message [40] = "Frost Prediction";
sms.SendSMS (number, message);
}
}
    
```

(d) **Database:** MySQL programming language was used to run on the client computer. The software architecture of the gateway is constructed as a relational database management system. Similar to the hardware and software of this system, the database architecture has been designed more simply. Fig. 6 shows the structure of the designed database as part of the employed software. The database system functions in a real-time manner. While the system operates based on the

continuous mode, the system receives real-time data (every 250 ms) and stores them in the relevant tables in the database. However, in the on-demand mode, the system receives data according to the operator's request. While the data are stored in tables, their values are relationally compared with the threshold values of the warning conditions, which are specified in the alarm table. Therefore, once each condition occurs, the system informs the operator by means of the provided methods (SMS or webpage). In Fig. 7 the functional flowchart of the overall system is depicted.

4.1.3. Connectivity capabilities

In this project, the nRF24L01 module was used for communication

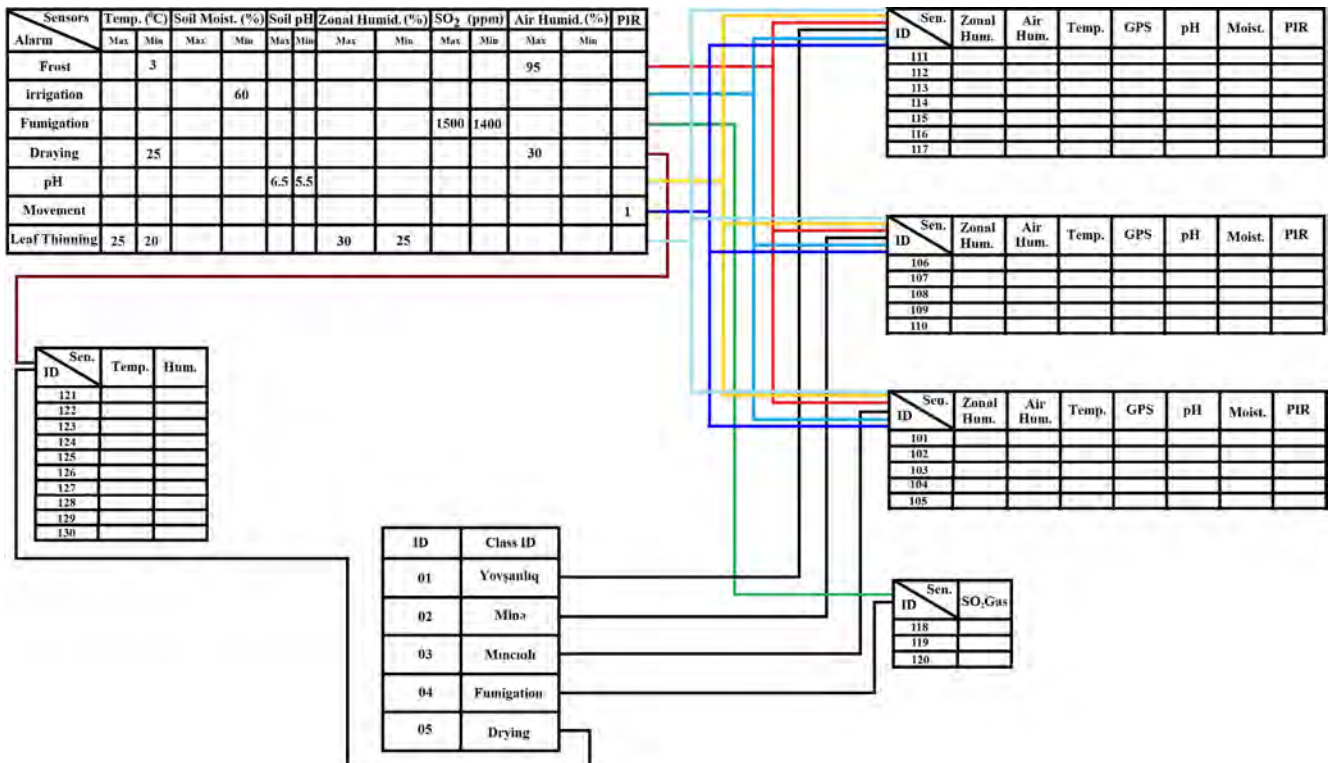

Fig. 6. The database structure of the gateway.

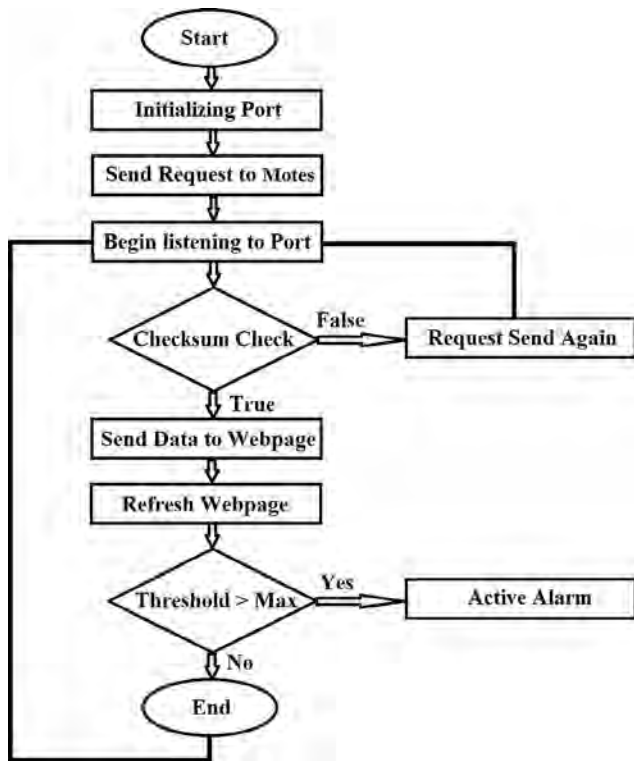

Fig. 7. The functional flowchart of the overall system.

and transmitting data between the EDs (motes), sink motes, and the gateway (base sink). The standard SPI protocol and pins (CSN, SCK, MOSI, MISO), with the additional CE (for controlling the RX/TX and standby modes) and IRQ signals (for informing the SPI master about the completion of a packet reception/transmission) are used by this chip. To ensure a smooth data flow between the radio front end and the system’s MCU (Master Control Unit) or the gateway, internal FIFO manages the data flow. Furthermore, communication between the gateway and the monitoring center is executed with Ethernet cable and Wi-Fi.

Communicational protocols used in this proposed monitoring system consist of the two following categories (Fig. 8):

- (1) The connection between the sink motes (of the EDs), the receiver circuit, and the Mini PC of the gateway: This connection between the sink motes of the EDs, and between sink motes and the receiver circuit, is performed based on SPI protocol. Using this protocol, it is possible to manage hardware-software properties (such as baud rate, bit rate, configuration register, etc.), to synchronize all EDs, sink motes (N1, N6, and N11 motes), and the gateway and to ensure receipt of the data (ack or nack). Moreover, the connection between the receiver circuit and the Mini PC of the gateway is performed using USB protocol. The USB is also a power resource for modules and Arduino boards. The C# coding language was used for port scanning functions, whereby the Mini PC scans the data (received

by the receiver circuit), puts them in the variables, and does the following operations: (a) using an Ethernet interface (or Wi-Fi), sends the data to the monitoring center and (b) stores the data in the database in order to access them as it is needed.

- (2) The mechanisms and protocols between the gateway and monitoring center: Ethernet port (using the network cable) and Wi-Fi were used for this kind of connectivity in order to enable the users to access the gateway. In addition, SMS sending and Bluetooth link capabilities are provided. Furthermore, the data aggregation task is performed simply and robustly. The gateway receives the EDs’ transmitted data and stores them in the database and the relevant tables.

4.1.4. Topology

Topology determines how the devices are interconnected. A star topology was used in this investigation. In this kind of topology, the gateway functions as a central processing unit so that it gathers sensor readings from all EDs. In a star topology, every sink mote is connected to a central node (gateway or MCU), which acts as a channel to transmit messages.

4.2. Energy

Sensing, computation, and radio operations such as receiving and transmitting are three types of activities that consume the majority of the power in a mote. Since radio operation activity uses the majority of the power, an energy efficient plot should be concentrated on decreasing the amount of time devoted to receiving and transmitting operations. The power consumption of a mote’s receiving activity is higher than the transmitting activity.

There are two modes of receiving and transmitting, wherein each mode has a different energy consumption level and has a direct effect on the network’s durability.

- (1) Continuous mode: In this method, the motes continuously send the data, and they have to be active and respond to the gateway’s requests. Obviously, in this mode, the lifetime of the motes and network will be decreased.
- (2) On-demand mode: During this mode, the motes are in the sleep condition. When the motes receive a request from the gateway they turn on and, having responded to the request, they return to the sleep mode. Accordingly, the network traffic is reduced because of the decrease in the sampling frequency. Hence, this mode has less energy consumption than the continuous mode, and the network’s lifetime is increased. Since the energy consumption in the WSN is the most challenging issue and the battery is a more common source of energy, using the best mode for optimizing consumption of energy is inevitable.

4.3. Stipulation and deployment

Before installing the system in the harsh and natural conditions of the vineyards, the system was tested under laboratory conditions between December 2015 and February 2016, in order to assay the accuracy and channel resolution of the motes and gateway boards. Subsequently, all the hardware were calibrated according to their data sheets and installed in the WSN. All the executable codes were manually downloaded into the associated microcontrollers of the motes. A unique identifier was attributed to each mote. Both the source and binary codes were checked in order to detect and correct faults and errors.

The energy source for the motes was provided in two methods and every method was evaluated and tested. For the EDs, two means of energy supply were used and tested: (1) rechargeable common batteries and (2) rechargeable lithium batteries. Since the power bank was utilized in the second method, the system was able to have an

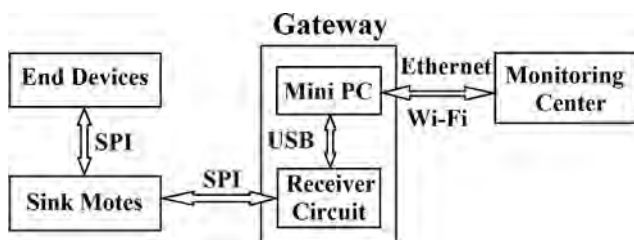

Fig. 8. Diagram of connection methods between the hardware.



Fig. 9. Network layout of a WSN system used in the vineyards. P1, P2, and P3 represent Yovşanlıq, Minə, and Mıncıqlı vineyards, respectively.

approximately one-month duration. However, for the gateway, DC power was used. Since the gateway had access to unlimited electricity, it was able to work permanently.

To create wireless connectivity, nRF24L01 was used. This module can transfer data in a 1600 m distance range and has “auto ack” capability, which provides certainty in receiving the data. For testing this module, one thread of data was sent 1000 m from the transmitter and on the other end, the data was received correctly without errors. Finally, by adding this module to the project’s board, the data were received singularly and wholly.

Accordingly, the sensor motes were physically located in the fields.

4.3.1. Vineyards

Having carried out the tests, the system components were implemented in the vineyards. Three disparate and distant experimental vineyards were used in the project (Fig. 9). The climates of these three vineyards were different. The climate of the first vineyard, named Yovşanlıq, is dry, the second vineyard (Mıncıqlı sector) is a medium climate, and the third one (Minə) is semi-humid. The cultivated grapes of the vineyards were white and red Thompson seedless grapes. However, the majority of the grapes were white (more than 98%). The area of the Minə, Mıncıqlı, and Yovşanlıq vineyards is $130 \times 138 \text{ m}^2$, $130 \times 141 \text{ m}^2$, and $210 \times 132 \text{ m}^2$, respectively. The vine trees in every vineyard were pruned during the spring. As is shown in Table 2, five motes were implemented in each the Minə and Mıncıqlı vineyards, and seven motes in the Yovşanlıq vineyard were in the desired spots (totally 17 motes). To protect the motes from rain and environmental damages, a package was designed to plug in the mote’s components. The motes were fastened to a bar with the height of 0.5 m to keep soil sensors close to both the ground and vines. The gateway was placed outside the vineyard in the monitoring site in order to evaluate the system’s performance in term of range, robustness, and flexibility and to assess the microclimatic variability corresponding to the management practices within the various areas.

Table 2
Sensor network architecture that was implemented in the fields.

Zone	Mote	ID	Measurement	Sensor board	Distance
Monitoring room	1	0	Gateway	–	–
Minə	5	101–105	Temperature, Humidity Position, Motion, pH	Arduino	1400 m
Mıncıqlı	5	106–110	Temperature, Humidity Position, Motion, pH	Arduino	1100 m
Yovşanlıq	7	111–117	Temperature, Humidity Position, Motion, pH	Arduino	950 m
Fumigation	3	118–120	Gas	Arduino	100 m
Drying	10	121–130	Temperature, Humidity	Arduino	100 m

4.3.2. Drying building

Thirteen motes were installed within the drying building, with three of them being used for the fumigation process and the remaining ten motes used for the drying process. For the fumigation process, just one sensor was used (SO_2 gas sensor), but for the drying process, two sensors including humidity and temperature were utilized.

Once the field tests, installation, and implementation processes were completed, the motes were activated and the WSN system was initiated. The data from each mote were received by the gateway (base station). Subsequently, the data were stored in a database in order to be processed and depicted in the web page. The updated data obtained from the vineyards were extracted and presented by the web page. The operator or vineyard owner exploits the provided information to make the right decisions and takes appropriate actions to handle and manage the problems and issues relevant to the vineyards. All the data received from the motes were stored in textual files in the database and were presented in the webpage in the monitoring center. This webpage is the software of the monitoring system, which is used for management. Storing the data in a text file in the database makes it possible to create graphs of hourly, daily or longer interval data reports and trends to analyze the environmental variables.

5. Experimental results and discussions

The designed system was user-friendly and easy to use. The web page (Figs. 10 and 11) provided the following main functions: real-time data, historical data, mote management, and user management. The user can observe the data from each sensor of the motes in real-time and access the historical data by selecting the time range for acquiring the data with a simple point-and-click. In addition, the mote management functions allow the user to check the status of the network and actual motes. By using this option, the user can check the condition of each mote in order to replace batteries or to troubleshoot the technical faults and re-deploy the troubled motes. The user can reach to every mote and observe each sensors’ data by means of the displayed charts and

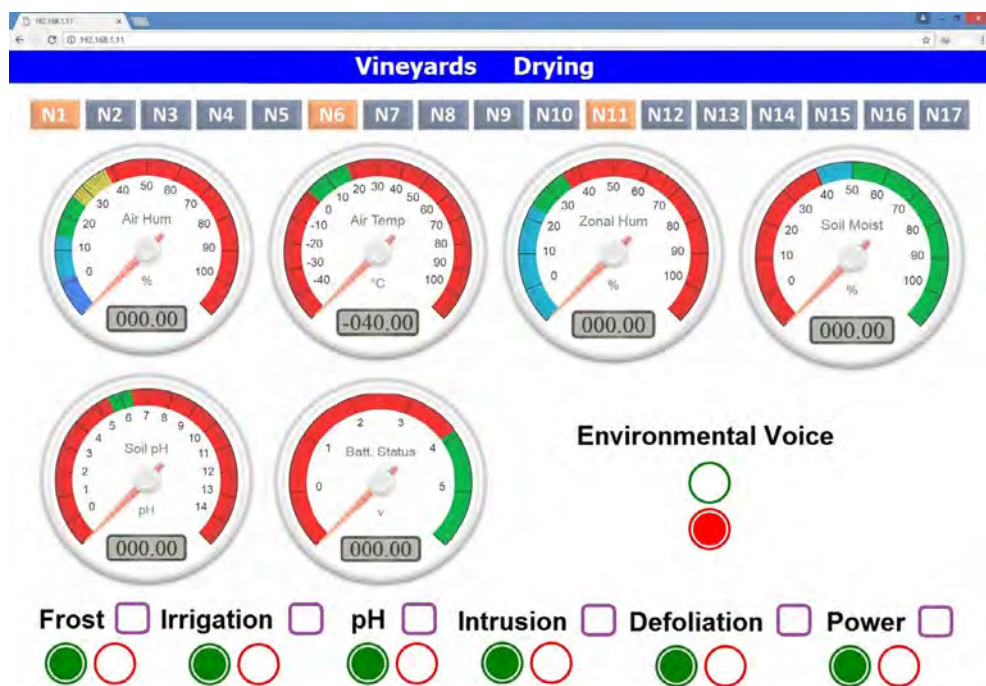

Fig. 10. Web page, displaying the vineyard notes (from N1 to N17).

numerical presentations. Moreover, a user carrying smart devices such as a smartphone, tablet, or PDA (via SMS and Wi-Fi) can monitor the state of the field and the in situ sensors.

In the proposed system, adding new notes can be done without further change or expense. Compared to the other proposed systems, changing the hardware-software architecture of the current system is not costly because it is not necessary to upgrade hardware boards or to change their programming logics. The gateway, despite having lower software-hardware complications, was able to operate all the desired functions and tasks in the traditional vineyards, and it monitored the defined warning conditions accurately.

Furthermore, using a Mini PC as the motherboard of the gateway obviated traditional systems' limitations. One of the conventional methods of designing a gateway board is to utilize an Ethernet shield or the RS232 connector, which has some disadvantages. For example, an

Ethernet shield has a lower speed, uses an SD card for saving the data and is limited in connection methods to the monitoring center. By using the Mini PC, these limitations were eliminated. Particularly, using the Mini PC in the proposed system was beneficial for enhancing the connection and communication capabilities and performance speed, reducing the SDOF (Single Point Of Failure) malfunction potentiality (by installing the security software), being used as the monitoring center (because of having of the HDMI interface), having remote access desktop capability (using remote access software tools such as TightVNC and so on), installing various desired software (due to possessing the Windows operating system), and getting access to the database comfortably and speedily.

Additionally, the operating system of the Mini PC is flexible and easily usable. Its OS toolsets are easily extensible to user's specific needs. Moreover, the communication stack in the default libraries has

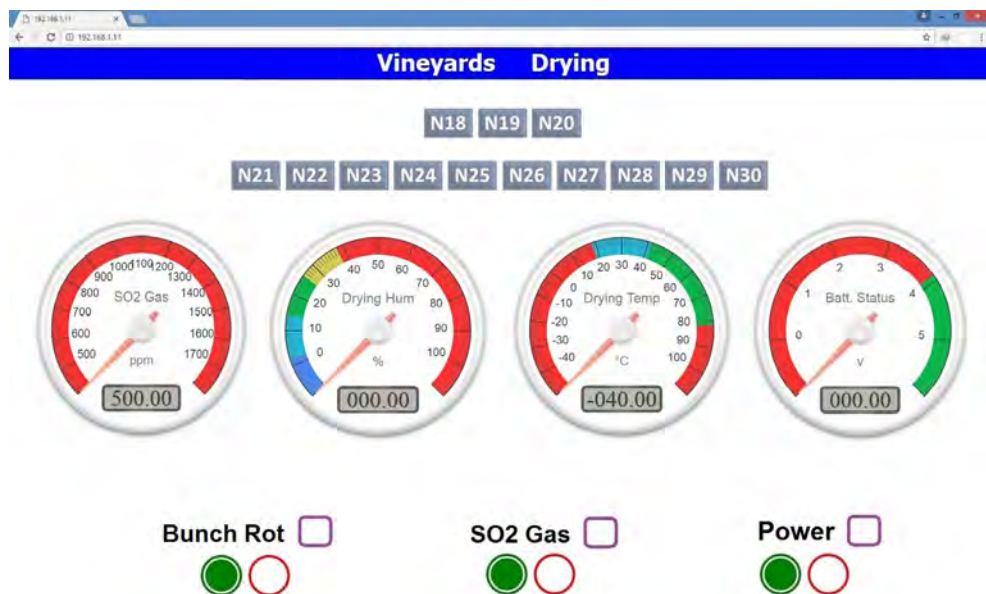

Fig. 11. Web page, displaying the drying structure notes (from N18 to N30).

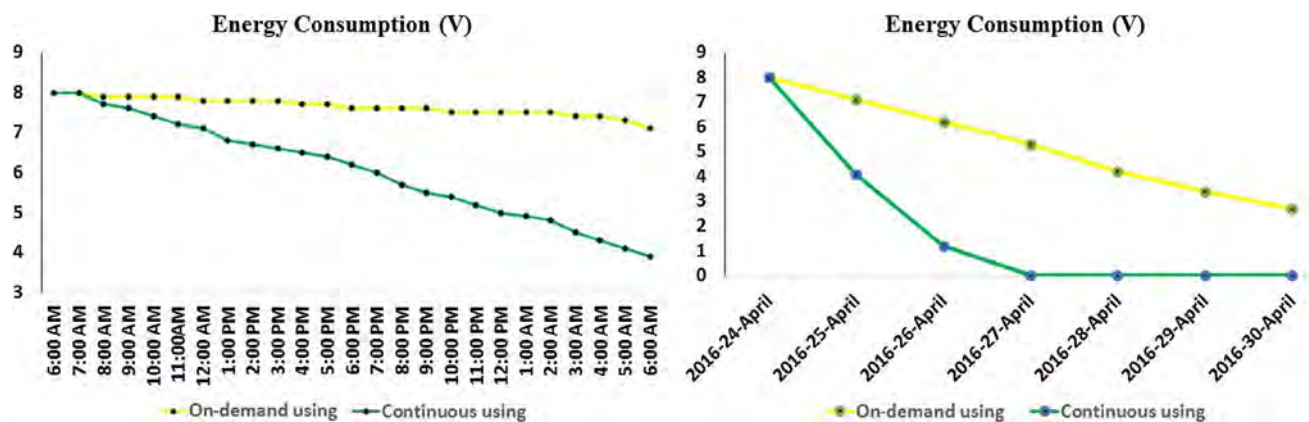

Fig. 12. Typical daily and weekly energy consumption of the used power supplies with continuous mode versus on-demand mode.

the considerable characteristics of usability, simplicity and resource efficiency so that the users can use it without extra complexity. External memory support for user data storage in the Mini PC is provided. The users do not have to worry about sensor data—they are depicted automatically. Finally, all the required software can be installed easily.

The tests pertaining to the energy consumption indicated that using common batteries makes the motes stable for one week. However, as shown in Fig. 12, by using an on-demand approach, the energy consumption of the batteries was decreased and their lifetime was increased. Fig. 12 shows a typical daily and weekly energy consumption of the utilized batteries with the continuous mode vs. the same application using the on-demand mode. As depicted in the figure, in comparison with the continuous mode, the lifetime of the system was increased by 43.75% using the power source with the on-demand mode. Additionally, when utilizing the power bank facilities, the lifetime of the batteries increased to one month. During continuous weeks of monitoring, every battery’s condition was monitored by the operator using the webpage in order to recharge or replace the weak batteries.

The results regarding the connectivity showed that the nRF24L01 modules were easily able to perform data transference with a 1600 m distance range. In addition, instead of using overpriced boards, these low-cost modules were utilized, and by modifying and changing their baud-rates and registers, it was possible to provide the modules’ performance analogous to the costly ones.

The results of the vineyards and drying process monitoring are detailed below.

5.1. Vineyards

The developed system was deployed in three vineyards located in Qurijan (Qurucan) village in South Azerbaijan. The system was used from March to November 2016. The farmers were using traditional irrigation methods within the vineyards. The prime objective of utilizing this technology was to provide predictive information about the gardens in order to improve the quality of the grapes and raisins. The measured parameters were humidity, soil pH and moisture, movement detection, GPS, and temperature. Data acquisition processes were mainly divided into the following seasons:

(1) **Spring** (lasting from March to June): During April, temperature and air humidity sensors were simultaneously activated in order to monitor variations in temperature and predict the frost. The sensors were demanded to monitor nocturnal and diurnal variation of the temperature and humidity from 20 o’clock until 8 o’clock in the morning (of the next day). Fig. 13 depicts two typical nightly and daily variation of the temperature and humidity in the vineyards. Three motes were selected from each vineyard (N2, N7, and N12 motes). It was observed that the hours near to dawn (between 4 and 6 o’clock) are the hours most at risk of frost damage. This means that during these hour

intervals, the vineyards are extremely susceptible to frost harm, which resulted from “radiation freezes”. Radiation freezes occur on calm, clear nights (without any clouds) when the heat from the ground radiates upward. Since the cold air is heavier than the warm air, it settles in areas of lower elevation. As the cold air stays low and the warm air rises, the air becomes stratified and a temperature inversion forms. Additionally, as seen in Fig. 13, before the break of dawn, the air humidity reaches its maximum range in the vineyards. Simultaneously, an increase in air humidity and a reduction in temperature can precipitate frost occurrence. The data from the sensors showed that Minə vineyard was the most vulnerable vineyard to the frost harm. Hence, it was suggested that the farmer install and apply frost protection equipment and methods during April (of every year) within the vineyards.

During this season, other sensors including humidity, PIR, GPS, and acoustic modules were active. A GPS sensor was installed on just one end device of every vineyard (N1, N6, and N11). The PIR sensor was utilized to protect the implemented end devices from intruders such as wild animals. During the season, no intruders were observed. Additionally, the acoustic modules were activated during May in order to record the sounds of depredating insects. During this month, the acoustic modules were activated daily around lunchtime. In Yovşanlıq vineyard, cricket songs were detected. Accordingly, insecticides were deployed to the vineyard in order to extirpate the nuisance insects. Furthermore, during this season, the pH sensors were turned on weekly in order to record soil pH variations.

(2) **Summer** (June to September): During this season, soil pH, soil moisture, temperature, and humidity sensors were active. Concurrently, acoustic modules were actively used. During these consecutive months, soil moisture records provided updated data in order to irrigate the vineyards. As shown in Fig. 14, continuous monitoring of the soil moisture level provided the data for scheduling irrigation times within each vineyard. The peak points in every linear graph indicate the times that the vineyards were irrigated. Minə and Mincıqlı vineyards were irrigated five times, but the Yovşanlıq vineyard was irrigated six times. The data indicate that because of the dry climate, water evaporation speed within Yovşanlıq vineyard is greater than in the other two vineyards. However, it is possible to accumulate and save moisture content by increasing irrigation duration and frequency. In addition, it was observed that while the irrigation duration increases, the moisture content also increases. This correlation demonstrates that longer irrigation times lead to the deeper penetration of water and higher moisture content.

In addition, during early June it was observed that the soil pH of Mincıqlı was trending towards alkalinity (Fig. 14). To lower the pH to 6.5 and 6, a urea fertilizer was used in the vineyard. As depicted in Fig. 14, applying a urea fertilizer had a significant effect on maintaining the desired soil pH level in Mincıqlı vineyard.

Furthermore, zonal (beneath leaves) humidity sensors were also

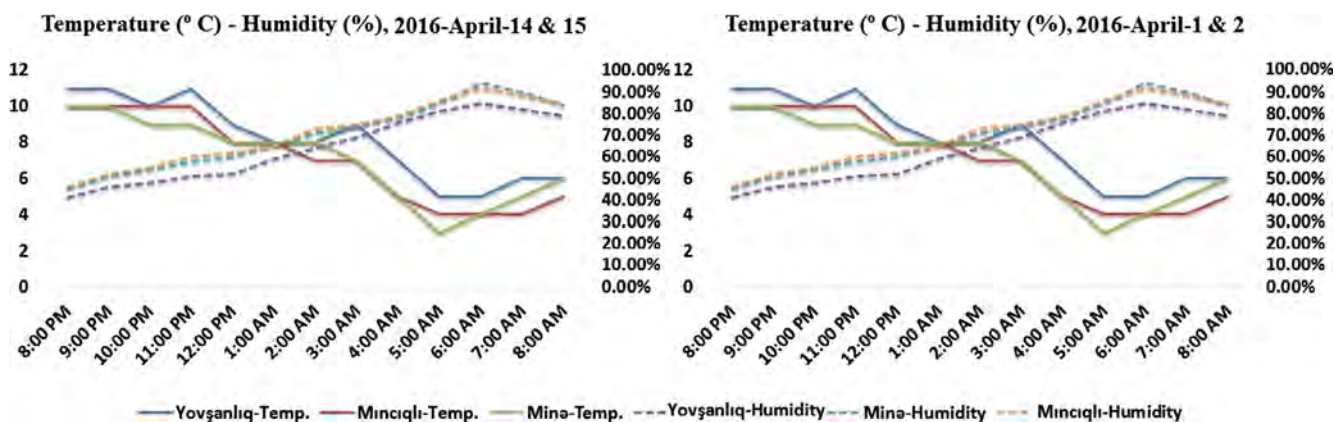

Fig. 13. Two typical nightly and daily variations in temperature and humidity in the vineyards.

active during the summer months. Zonal humidity (spaces under the leaves) is extremely critical during August and September. As presented in Fig. 15, in Minə and Mincikli vineyards, the zonal humidity was observed to be increased on 4 and 7 August, respectively, during which the farmer received the warning alarms via SMS. To avoid being exposed to probable fungal diseases, the leaves of the vines were thinned by the employed artisans. However, for Yovshanliq vineyard, since the air temperature was immoderate, in order to protect the grape bunches from sun burning damage, the leaves were not thinned.

It has been found that temperature and humidity are the most crucial parameters for improving the quality of the final products. In the cases of Minə and Mincikli vineyards, humidity had the highest effects, whereas in Yovshanliq vineyard, the temperature had the paramount importance. Another conducive parameter with a direct impact on the quality of the grapes and raisins is the sugar level of the berries. Since the WSN reported excessive zonal humidity (between the leaves and the face of Qanas) of Minə and Mincikli vineyards, the leaves were trimmed in order to increase the amount of sunlight received by the vines. Consequently, the sugar level, flesh, and volume of the mature berries increased. However, because of the inherently dry climate of Yovshanliq vineyard, the leaves of the vines were not trimmed. Accordingly, the schedule of harvesting time was determined and postulated by the system, resulting in the farmer first harvesting Yovshanliq vineyard in early September and Minə and Mincikli vineyards in late September.

5.2. Drying structure

The WSN system was used during October in order to monitor the fumigation and drying processes. In the fumigation process, three motes were utilized in every round of fumigation. To keep even and uniform

diffusion, circulation, and concentration of the SO₂ gas through the grape bunches, the motes were used in three disparate sections of the fumigation chamber inside the covering nylon. The motes were used in every round of fumigations. Using the WSN system, direct-close inspection and monitoring procedures were eliminated. Fig. 16 displays continuous monitoring for a typical round of the fumigation process. The webpage provided continuous monitoring via the relevant diagram and warning system. Additionally, the SMS module sent alarms in case of inordinate and lesser amounts of SO₂ gas. As seen in Fig. 16, after 30 min, the amount of SO₂ gas was decreased to 1392 ppm (57,907.2 μmol m⁻³). The operator received this inconvenient insufficiency by SMS, and, subsequently, an amount of sulfur powder was added to the sulfur container inside the chamber. This calibrated amount of sulfur powder was consumed in the next round.

After every fumigation round, the nylon was unwrapped in order to let atmospheric air circulate through the grapes inside the building. One mote was implemented between every two columns in the back side beyond the hung grapes (between the wall and suspended grape bunches), where it is not approachable or accessible (Fig. 2). Generally, 10 motes were used inside the building during October and November in various locations of the drying building (structure). The humidity and temperature of the inside building were continuously monitored. During late October, since the air temperature plummeted in the region, the online warning system sent a rot prediction alarm via SMS and webpage. Subsequently, the raisin producers avoided the problem by providing a constant ventilated hot air flow inside the drying structure at 60 °C. Finally, in November, all the produced raisins (at 18% moisture content level) were gathered and stored in the storage room.

The result showed that applying the WSN monitoring system in the vineyards and drying structure increased the quantity and quality of the grapes and final products. Particularly, grape and raisin production

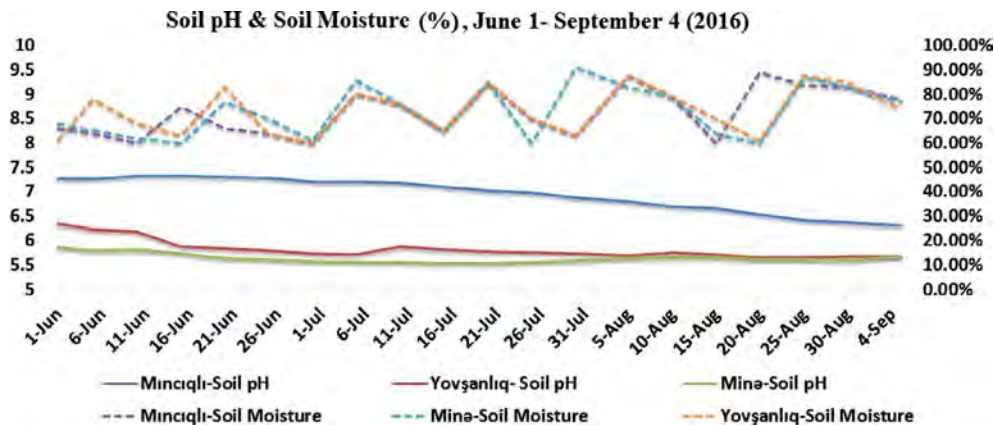

Fig. 14. Continuous monitoring of the soil moisture and soil pH.

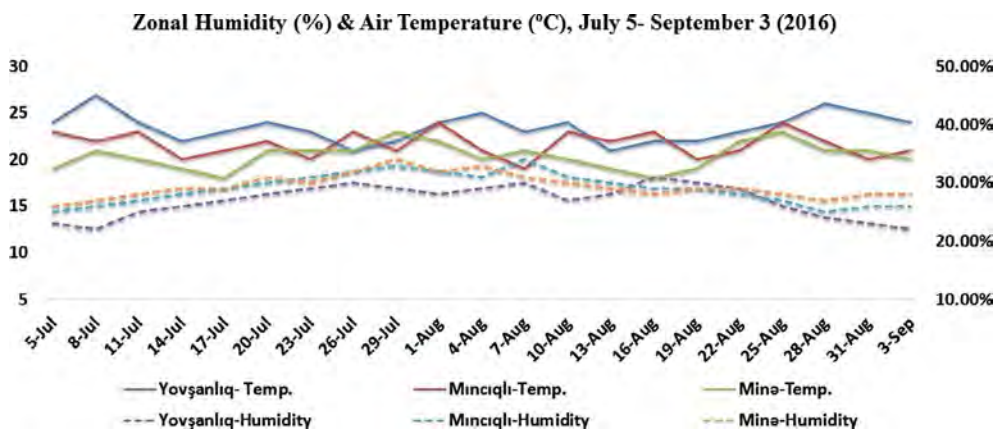

Fig. 15. Zonal humidity and temperature.

yield was increased 4 t/ha compared to the yield of the year before. Grape yield depends greatly on cultivation and climatic conditions and varies from one variety to another. This leads to a wide range of yields across the world: from 6 to 12 t/ha in France to 20–30 t/ha in the USA, especially in California (<http://www.oiv.int/public/medias/4911/fao-oiv-grapes-report-flyer.pdf>). According to the Ministry of Agriculture, the average yield of grape production in Iran is approximately 12 t/ha. In comparison with the average national yield, the yield was nearly increased to 6 tons per hectare (0.544 kg/m²). This means that the system was able to increase the yield more than 28%. Furthermore, inside the drying structure, raisins were produced without any dissipating damages stemmed from excessive fumigation or fungi.

6. Conclusion

This paper shows WSN-based precision viticulture in traditional vineyards and drying processes. The system was developed on the basis of other successful experiences with wireless sensor network systems and decision-making supports in agriculture. The main components of the system are a gateway (composed of a Mini PC and receiver circuit) and thirty peripheral motes with installed relevant modules (nRF24L01 module, VS1003 acoustic module, GSM module, and GPS receivers) and sensors including temperature, humidity, soil pH and moisture, SO₂ fumigation, and PIR. To display and browse the data, a web interface (Graphical User Interface; GUI) was designed to provide the vineyard locations on Google Maps, the graphical representations, the gauge charts, and the numerical data display. The webpage provides the desired data at the user's request with simple clicks. The experimental results proved that the system reliably and satisfactorily performs the desired duties with simple architecture and devices and at reasonable prices.

considerable advantages such as a lower implementation cost, extended capabilities and easy changing of software-hardware, and being user-friendly, portable, and easy to use. Particularly, the proposed system offers great flexibility for using continuous modes and on-demand requests based on pooling mechanism. The results indicate that by using the system with an on-demand approach, the lifetime of the motes and the utilized power supply is increased. The implemented approach accuates the motes at the user's demand to switch their sleeping/active modes whenever they are needed and to consequently save the energy supply.

The system is able to predict imminent frost using real-time data of temperature and air humidity sensors located in the vineyards. By measuring the soil moisture and air humidity parameters, the system provides feasibility of scheduling the irrigation frequency. More importantly, the system is able to determine the optimum irrigation duration for each vineyard according to their climatic conditions. The overall results imply that since the amount of irrigated-evaporated water is high, flood irrigation (traditional irrigation) is not an efficient method.

By obtaining soil pH data, the system is able to predict, warn, and monitor the nutrition deficiencies of the terrain. Furthermore, by measuring the data of the zonal (between the surface of the 'Qana' and leaves) humidity sensors, the system is able to prevent probable fungal diseases and sun burning damages. Consequently, the leaves controlling procedure is decided by the farmer so that in the case of immoderate humidity, the leaves of the vines can be thinned and in the case of too much heat, the leaves can remain untouched. As a result, the vineyards that receive more controlled sunlight grow larger berries. Finally, using the data obtained from the vineyards, the system can predict and schedule the harvesting time.

Regarding the drying building (structure), the fumigation process can be continuously monitored in order to control the amount of SO₂

Using a Mini PC as the motherboard of the gateway has some

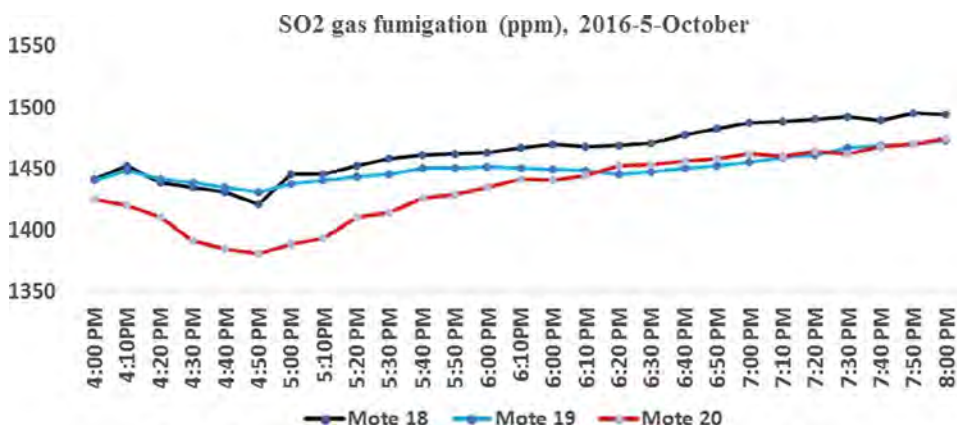

Fig. 16. Continuous monitoring for a typical round of the fumigation process.

gas inside the fumigation chamber. Importantly, by monitoring the process, the farmer can calibrate the amount of sulfur powder used. Subsequently, by continuously monitoring the humidity and temperature inside the building, the system can detect and predict the imminent rot damage. These experimental results suggest that a traditional drying building equipped with the proposed WSN-based system can serve as a useful platform for monitoring the drying process and subsequently for increasing the quality of the produced raisins.

Finally, the proposed system is helpful for increasing the quality and quantity of the grapes and raisins. It is able to prevent probable diseases, foresee the nutrition demands, schedule and determine irrigation duration and frequency, and warn of predating insects. Specifically, by using the WSN data, farmers are able to schedule harvesting time based on maturity, quality, and productivity.

7. Future improvements

This project can be extended in future studies in order to improve the system in various domains such as

- (1) The online warning system was not able to generate an alarm warning of the presence of nuisance insects. This warning system needs a comprehensive signal processing research project in order to detect and distinguish the depredating insect sounds from other environmental sounds. Moreover, an image processing method can be added to the system for recognizing deficiencies, pests, diseases, and other detrimental agents in the vineyards.
- (2) Sap-flow measurements as an indicator of vine transpiration and plant water status throughout the season can provide an alternative tool to optimize and manage irrigation. In future work, this method can be applied in the current WSN system.
- (3) Luminosity as a key factor of brightness analysis for estimating light radiation on plants can be applied for determining the sugar concentration, controlling the amount of sunlight received by the vines, and determining the optimum time for harvesting more accurately and timely. Furthermore, by utilizing light sensors, the WSN system can detect the presence of clouds or rain that are extremely deleterious during harvesting time.
- (4) Future studies can be focused on applying automated control for decision support systems through integration with an automatic irrigation system, frost preventing system, SO₂ fumigation system, nuisance insect extirpating system, etc. The control commands can be counted in a locally centralized manner and then transmitted wirelessly to the actuators located in the vineyards and drying structures.
- (5) The dried raisins are stored in bulk (in the storage or packing house) before further processing. The raisins should be stored in cool, dry rooms. Specifically, the equilibrium moisture content (EMC), the point at which the raisins are neither gaining nor losing moisture, is important. The value of the EMC depends on the material and the relative humidity and temperature of the air. To maintain such equilibrium in moisture content of the stored raisins and to monitor the other parameters of the stored raisins, a WSN can be applied inside the storage or packing houses.

References

Beckwith, R., Teibel, D., Bowen, P., 2004. Report from the field: results from an agricultural wireless sensor network. In: Proceedings of the 29th Annual IEEE International Conference on Local Computer Networks. IEEE Computer Society, Washington, DC, USA, pp. 471–478.

Burrell, J., Brooke, T., Beckwith, R., 2004. Vineyard computing: sensor networks in agricultural production. *Pervasive Computing* 3 (January–March (1)), 38–45.

Coates, R.W., Delwiche, M.J., Broad, A., Holler, M., 2013. Wireless sensor network with irrigation valve control. *Comput. Electron. Agric.* 96, 13–22.

Das, I., Naveen, C.P.R.G., Yadav, S.S., Kodilkar, A. A., Shah, N. G., Merchant, S.N., Desai, U.B., (2009). WSN monitoring of weather and crop parameters for possible disease risk evaluation for grape farms-sula vineyards, a case study. In: Proceedings of

Conference on Geospatial Technologies and Applications (Geomatrix), IIT Bombay, Mumbai, India, 27–29.

Dobbs, N., Migliaccio, K.W., Li, Y., Dukes, M.D., Morgan, K.T., 2014. Evaluating irrigation applied and nitrogen leached using different smart irrigation technologies on bahiagrass (*Paspalum notatum*). *Irrig. Sci.* 32, 193–203.

Fernandes, M.A., Matos, S.G., Peres, E., Cunha, C.R., Lopez, J.A., Ferreira, P.J.S.G., Reis, M.J.C.S., Morais, R., 2013. A framework for wireless sensor networks management for precision viticulture and agriculture based on IEEE 1451 standard. *Comput. Electron. Agric.* 95, 19–30.

Franck, J., Latorre, B.A., Torres, R., Zoffoli, J.P., 2005. The effect of preharvest fungicide and postharvest sulfur dioxide use on postharvest decay of table grapes caused by *Penicillium expansum*. *Postharvest Biol. Technol.* 37, 20–30.

Garcia-Sanchez, A.J., Garcia-Sanchez, F., Garcia-Haro, J., 2011. Wireless sensor network deployment for integrating video-surveillance and data-monitoring in precision agriculture over distributed crops. *Comput. Electron. Agric.* 75 (2), 288–303.

Goumopoulos, C., O'Flynn, B., Kameas, A., 2014. Automated zone-specific irrigation with wireless sensor/actuator network and adaptable decision support. *Comput. Electron. Agric.* 105, 20–33.

Hwang, J., Shin, C., Yoe, H., 2010. Study on an agricultural environment monitoring server system using wireless sensor networks. *Sensors* 10, 11189–11211.

Jiang, J.A., Lin, T.S., Yang, E.C., Tseng, C.L., Chen, C.P., Yen, C.W., et al., 2013. Application of a web-based remote agro-ecological monitoring system for observing spatial distribution and dynamics of *Bactrocera dorsalis* in fruit orchards. *Precis. Agric.* 14 (3), 323–342.

Karimi, N., 2015. Moisture-dependent physical properties of seedless and seeded raisin (*Vitis vinifera* L.) varieties. *Lithuanian J. Agric. Res.* 16(1), 5–16. <http://dx.doi.org/10.1515/cerce-2015-0012>.

Karimi, N., Arabhosseini, A., Kianmehr, M.H., Khazaei, J., 2011. Modeling of raisin berries by some physical and statistical characteristics. *Int. Agro Phys.* 25 (2), 141–147.

Karimi, N., Karimi, M., Karimi, M., Hüseyinov, R., 2015. Statistical and physical characteristics for separation defective berries of seeded and seedless raisin varieties. *J. Food Process Eng.* 38 (2), 162–173.

Karimi, N., Ranjbar, R., Alizadeh, T., 2017. An intelligent system for quality measurement of Golden Bleached raisins using two comparative machine learning algorithms. *Measurement* 107, 68–76.

Kim, Y., Evans, R.G., Iversen, W.M., 2008. Remote sensing and control of an irrigation system using a distributed wireless sensor network. *IEEE Trans. Instrum. Meas.* 57 (7), 1379–1387.

López-Riquelme, J.A., Soto, F., Suardiáez, J., Sánchez, P., Iborra, A., Vera, J.A., 2009. Wireless Sensor Networks for precision horticulture in Southern Spain. *Comput. Electron. Agric.* 68 (1), 25–35.

Matese, A., Di Gennaro, S.F., Zaldei, A., Genesio, L., Vaccari, F.P., 2009. A wireless sensor network for precision agriculture: the NAV system. *Comput. Electron. Agric.* 69 (1), 51–58.

Morais, R., Fernandes, M.A., Matos, S.G., Seroido, C., Soares, F.S.P., Ferreira, P.J.S.G., Reis, M.J.C.S., 2008. A ZigBee Multi-powered wireless acquisition device for remote sensing applications in precision viticulture. *Comput. Electron. Agric.* 62 (2), 94–106.

Nikolidakis, S., Kandris, D., Vergados, D.D., Douligeris, C., 2015. Energy efficient automated control of irrigation in agriculture by using wireless sensor networks. *Comput. Electron. Agric.* 113, 154–163.

Reiser, D., Paraforos, D.S., Khan, M.T., Griepentrog, H.W., Va'zquez-Arellano, M., 2017. Autonomous field navigation, data acquisition and node location in wireless sensor networks. *Precis. Agric.* 18 (3), 279–292.

Rossi, V., Giosué, S., Caffi, T., 2010. Modelling plant diseases for decision making in crop protection. In: *Precision Crop Protection – the Challenge and Use of Heterogeneity*, pp. 241–258.

O'Shaughnessy, S.A., Evett, S.R., Colaizzi, P.D., Howell, T.A., 2013. Wireless sensor network effectively controls center pivot irrigation of sorghum. *Appl. Eng. Agric.* 29, 853–864.

Pan, L., Adamchuk, V.I., Martin, D.L., Schroeder, M.A., Ferguson, R.B., 2013. Analysis of soil water availability by integrating spatial and temporal sensor-based data. *Precis. Agric.* 14, 414–433.

Park, D.-H., Park, J.-W., 2011. Wireless sensor network-based greenhouse environment monitoring and automatic control system for dew condensation prevention. *Sensors* 11, 3640–3651.

Peres, E., Fernandes, M.A., Morais, R., Cunha, C.R., Lopez, J.A., Matos, S.R., Ferreira, P.J.S.G., Reis, M.J.C.S., 2011. An autonomous intelligent gateway infrastructure for in field processing in precision viticulture. *Comput. Electron. Agric.* 78 (2), 176–187.

Pierce, F.J., Elliott, T.V., 2008. Regional and on-farm wireless sensor networks for agricultural systems in Eastern Washington. *Comput. Electron. Agric.* 61, 32–43.

Santos, I.M., Guzzo da Costa, F., Cugnasca, C., Ueyama, J., 2014. Computational simulation of wireless sensor networks for pesticide drift control. *Precis. Agric.* 15 (3), 290–303.

Shah, N.G., Desai, U.B., Das, I., Merchant, S.N., Yadav, S.S., 2009. In-field wireless sensor network (WSN) for estimating evapotranspiration and leaf wetness. *Int. Agric. Eng. J.* 18 (3–4), 43–51.

Srbínovska, M., Gavrovski, C., Dimcev, V., Krkoleva, A., Borozan, V., 2015. Environmental parameters monitoring in precision agriculture using wireless sensor networks. *J. Cleaner Prod.* 88, 297–307.

Šrobárová, A., Kakalikova, L., 2007. Fungal diseases of grapevines. *Euro. J. Sci. Biotechnol.* 1 (1), 84–90.

Sun, Y., Zhou, H., Qin, Y., Schulze Lammers, P., Berg, A., Deng, H., Cai, X., Wang, D., Jones, S.B., 2014. Horizontal monitoring of soil water content using a novel automated and mobile electromagnetic access-tube sensor. *J. Hydrol.* 516, 50–55.

Togami, T., Yamamoto, K., Hashimoto, A., Watanabe, N., Takata, K., Nagai, H., Kameoka, T., 2011. A Wireless Sensor Set work in a vineyard for Smart Viticultural Management. 2011 Proceedings of SICE Annual Conference Tokyo 2011, 2450–2454.

Winkler, A.J., 1963. *Gen. Viticult. Jacaranda*, Milton, Qld.