



8th International Congress of Information and Communication Technology, ICICT 2019

# Modeling and Simulation of Turret Stabilization with Intelligent Algorithms

Ahmet Can Ceceloglu<sup>a1</sup>, Tulay Yildirim<sup>b</sup>

*Yildiz Technical University, Istanbul 34220, Turkey<sup>a</sup>*

*Yildiz Technical University, Istanbul 34220, Turkey<sup>b</sup>*

## Abstract

In this work, we study the problem of high precision turret control. Several control design strategies are applied to turret system to determine the applicability of each control design method and to characterize the achievable performance of turret system in precision control. A mathematical model of the turret is developed using state space equations. An intelligent controller has been developed for the stabilization of turret system with uncertain external disturbances. As an intelligent system is developed with Neural Network PID controller. MATLAB/Simulink and Neural network toolbox is used to set up application of turret system.

© 2019 The Authors. Published by Elsevier Ltd.

This is an open access article under the CC BY-NC-ND license (<https://creativecommons.org/licenses/by-nc-nd/4.0/>)

Selection and peer-review under responsibility of the 8th International Congress of Information and Communication Technology, ICICT 2019.

*Keywords:* Turret, PID Control, Neural Network, Stabilization

## 1. Introduction

Recently developed turret systems are used both mechanically and electronically. These systems can be placed on armored personnel carriers and battle tanks and are used to adjust the movement of ammunition to the target. The measurement of the distance between the target and the turret system can be measured by laser or optical methods prior to the calculated ballistic values to ensure correct ammunition movement. At the same time, meteorological sensors on turret systems also contribute to the ballistic account with the measured values. Recently developed turret systems have automatic target tracking for moving targets and have high accuracy firing [1]. In addition, the day and night vision of the surveillance systems in the turret systems ensures high ignition sensitivity at any time and any time. One of the most important features of turret systems is that they provide high firing accuracy when moving under difficult terrain conditions. This is achieved by the high stability of the system.

The ability of the turret sub-systems to have a high level of mobility and firing capabilities is mainly achieved by weapon stabilization takes place with the current base reference value of the barrel, although it is under distortions coming from the vehicle moving on a smooth or damaged land on the turret system. The task of performing the stabilization of turret subsystems; Control algorithms are complex in terms of coordinated operation of system nonlinearity and other units. External distortions are directly based on the external environment and this affects the disturbance frequency and amplitude. From the past to the present, PID

<sup>1</sup> \* Corresponding author. Tel.: +09-544-215-1213.

E-mail address: [ahmetcanceceloglu@hotmail.com](mailto:ahmetcanceceloglu@hotmail.com)

controller has been used as a turret controller and it is still used. The PID controller sends the torque command to the motor side by passing the speed command from the user and the difference in speed measured by the sensors through appropriate mathematical expressions [2].

While this controller has many advantages, it does not meet the high performance criteria for complex control structures. Therefore, new approaches are directed to artificial intelligence, which is the most common subject of recent times. In order to make the control system more efficient, the control coefficients of the PID controller are adjusted with multilayer artificial neural networks. The network is trained with the back propagation learning algorithm to minimize control error. The input and layer numbers of this network are obtained by creating a mathematical model of turret systems and optimizing them on appropriate simulation programs.

As a summary, the control tasks required to stabilize turret systems and have a high firing rate are very difficult due to the challenges of today's battlefields. The uncertainties of the controlled system and the changes in the non-linear and operational environment also increase the complexity of the control task. Thus, the main purpose is to minimize control error under rough conditions from random terrain [1].

In this work, we study stabilization for model of gun elevation axis by using PID Neural Network. We have developed a different approach to further reduce the stabilization accuracy value. In section 2, we explain the structure of Turret systems and what we actually doing for this system. Next, the plant of system is created for the control systems in section 3 and the intelligence system is showed with figures and formulas in section 4. We then present the simulation results using conventional PID and PID-NN in section 5.

## 2. Structure and working principles of Turret Stabilization Systems and Intelligence

The controller used for stabilization in most of the turret systems created with the latest technology is based on the classic PID controllers. The structure of the PID controller may vary depending on the structures of the systems to be used, and in the case of motor applications, the derivative part is generally ignored, and the PID controller is used as the PI controller. High pass, low pass and notch filters are used to eliminate the sensor noises used on the system and to avoid the resonance caused by the mechanical structure. The turret stabilization is provided along both elevation and azimuth axis of the main weapon. In this approach according to classical methods, the study of learning algorithms is important in order to detect changes in the turret environment and to re-adjust the control values accordingly to optimize stabilization performance.

Any system can be described as independent in an unknown environment when it has the ability to act properly for a long time without external interference. An intelligent system is based on skills such as perception, learning, reasoning, and inference or decision-making from missing or ambiguous information. The ability of an intelligent turret system to act appropriately in the face of any external disturbances that may occur means that the ultimate goal is not to reduce the high-shot sensitivity. This is very logical for turret systems because a small error can result in the loss of the crew in the turret sub-system. Learning techniques used in this study are indicated together with necessary pictures. Also; the parameters used in intelligent control and artificial neural networks are given to the importance and needs [1], [2].

## 3. Modeling of Control System

The gun elevation approaching model has been shown in Fig. 1. The coefficients used in this model are; the applied torque is  $T_d$ , elevation driveline stiffness is  $k_d$ , elevation drive viscous damping coefficient is  $c_d$ , elevation drive inertia is  $I_d$ , angular displacement of driveline is  $\theta_d$ , angular displacement of gun is  $\theta_g$ , Inertia of gun  $I_g$ , viscous damping coefficient of gun is  $c_g$ .

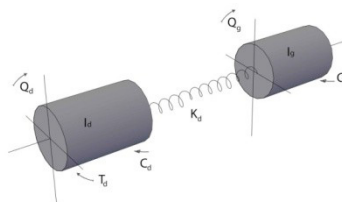

Fig.1. Approaching of Gun Elevation model [3]

Rotational dynamics for the elevation drive equations, [3]

$$I_d \ddot{\theta}_d = T_d - c_d \dot{\theta}_d - k_d(\theta_d - \theta_g) \quad (1)$$

$$I_g \ddot{\theta}_g = k_d(\theta_d - \theta_g) - c_g \dot{\theta}_g \quad (2)$$

State variables,

$$x_1 = \theta_d, x_2 = \dot{\theta}_d$$

$$x_3 = \theta_g, x_4 = \dot{\theta}_g$$

$$\dot{x}_1 = x_2 \quad (3)$$

$$\dot{x}_2 = 1/I_d \{-k_d x_1 - c_d x_2 + -k_d x_3 + T_d\} \quad (4)$$

$$\dot{x}_3 = x_4 \quad (5)$$

$$\dot{x}_4 = 1/I_g \{k_d x_1 - k_d x_3 - c_g x_4\} \quad (6)$$

The state-space equations are derived for elevation dynamics,

$$A = \begin{bmatrix} 0 & 1 & 0 & 0 \\ -K_d/I_d & -C_d/I_d & K_d/I_d & 0 \\ 0 & 0 & 0 & 1 \\ K_g/I_g & 0 & -K_g/I_g & -C_g/I_g \end{bmatrix}$$

$$B = \begin{bmatrix} 0 \\ 1/I_d \\ 0 \\ 0 \end{bmatrix}$$

$$C = \begin{bmatrix} 0 & 0 & 1 & 0 \\ 0 & 0 & 0 & 1 \\ 0 & 1 & 0 & 0 \end{bmatrix}$$

$$D = 0$$

The elevation dynamics comprise 3 degree of freedom, arising from the angular displacements of breech, muzzle and drive [4][5]. In the present math model of turret elevation system is shown above. The stabilization of elevation axis more important than azimuth axis because, the uncertain disturbances directly affect elevation axis. So, we focus on this issue.

#### 4. Algorithm Simulation and Results of Intelligence Turret Systems

Before starting adjusting control parameters, the turret system's chirp signal response should be seen. Because, mechanical effects are playing important role for turret system [3]. If there is a problem in chirp signal response as seen on Fourier transform, a notch filter or a better mechanical component should be used.

As seen below, the purpose our system's fft response of chirp signal is shown. So, our component is seemly good. We do not use any notch filter.

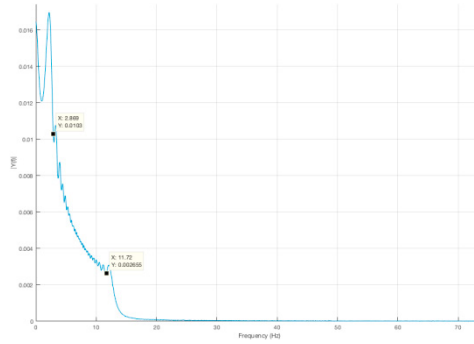

Fig. 2. FFT response of system of chirp signal effect

The control of structure of the gun turret systems consists of PID controller and Neural Network PID controllers to stabilize the velocity of turret systems.

The back propagation neural network used for the tuning of the gains of the PID controller consists of an input, an output and hidden layers. For creating inputs to the neural network design; error between reference and velocity of gun, output of controller and velocity of gun are selected as shown in Fig. 3.

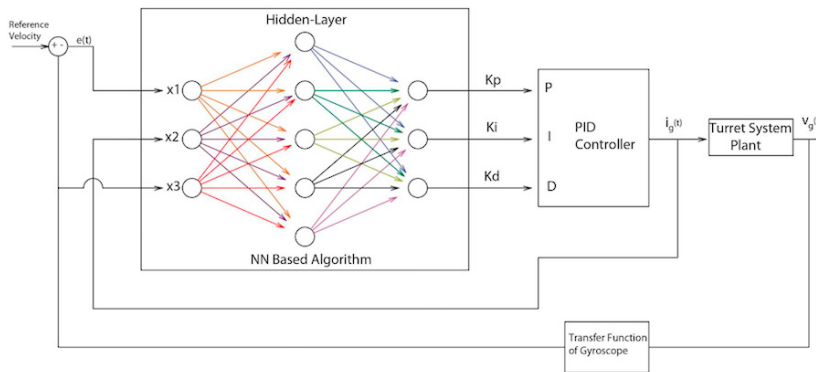

Fig.3. Detail of How to Adjusting Torque Signal

Comparable graphs for Conventional and Intelligent PID Controllers also are shown in Fig. 4 and Fig. 5. These figures indicate that, using intelligent system which adjusts PID parameters with neural networks make a better stable.

In the graphs, with the traditional PID controller used on the model of the gun elevation axis, gyro for the angular velocity values on the barrel, the encoder speed with the angular displacement derivative on the rotor, the disturbance value acting on the turret weapon system and in order to provide the stabilization the reference value and the angular velocity measurement difference values are shown.

When conventional PID controller is used, it is seen that error overshoot value is less than developed method, but settling time value is shorter. This study, which is based on the ITAE criterion for controller comparisons, has also been discussed and it has been shown that the developed method gives better results.

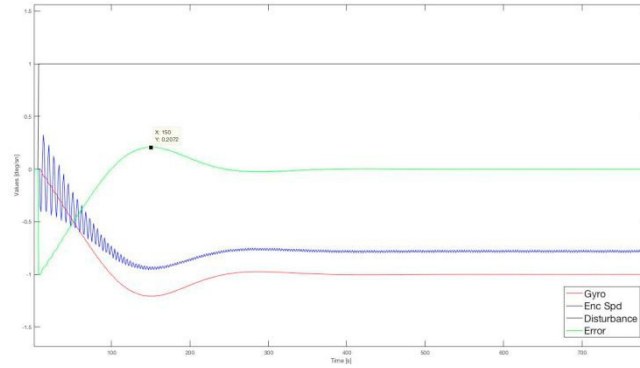

Fig. 4. Used Conventional PID Controller

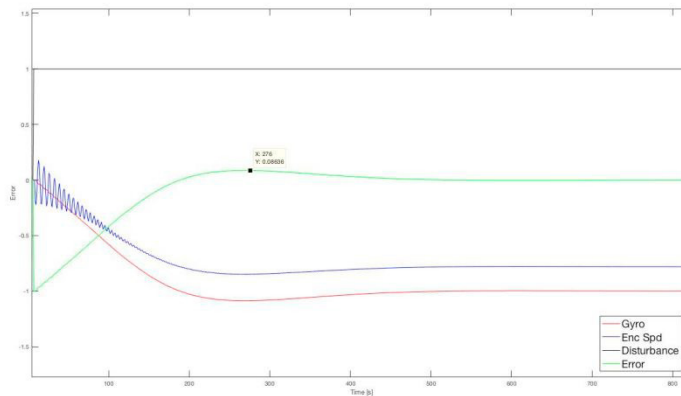

Fig.5. Used Intelligent PID Controller

The fact that the integral value of the time-weighted absolute error (ITAE) is as low as possible is generally indicated as a good performance indicator in the PID controller design. The advantage of the ITAE criterion calculated here is to change the system response to the control parameters and to determine the good or bad effect. As stated, the smaller the ITAE criteria, the better the control parameters used in that system [6].

$$\text{ITAE Criteria} = \int_0^{\infty} t|e(t)dt|$$

Therefore, main results and parameters values for both controller and mathematical model of elevation are shown in Table 1.

Table 1. Compared Results between conventional and intelligent control algorithms

Final Patch	P	I	ITAE	Epoch	Learning Rate
Conventional PID	9	18	257.4044	-	-
NN PID	5.81	18.9	173.9759	5000	0.4

## 5. Conclusions

In this study, an intelligent controller has been developed for the stabilization of the turret systems operating under any disruptive land and compared with the existing studies. The developed controller was analyzed on the elevation axis mathematical model of turret systems. We designed the intelligent algorithms and carried out simulation on the model in MATLAB/Simulink. It could be seen that the control value could reach the set velocity value stably. According to the results of classical methods and developed method control algorithms, it is seen that although the error function overshoot value is higher in the classical method, the settling time value is

smaller. The results show that the proposed controller performance can reach the desired stabilization aims values with less overshoot. Also it is seen, the stability of NN-PID controller better than PID controller.

## **References**

1. ÖzdemirGümüşay, 'Intelligent Stabilization Control of Turret Subsystems Under Disturbances from Unstructured Terrain', Master Thesis of Middle East Technical University, 2016.
2. Çağıl Çiloğlu, 'Dynamic modelling and analysis of gun turret elevation drive system', Master Thesis of Middle East Technical University, 2016.
3. Purdy, J., David, 'Main Battle Tank Stabilization Ratio Enhancement Using Hull Rate Feedforward', Journal of Battlefield Technology, Vol. 1, No. 2, pp. 5-9, July 1998.
4. AmbarishJakati, Saayan Banerjee, C. Jebaraj, 'Development of Mathematical Models, Simulating Vibration Control of Tracked Vehicle Weapon Dynamics', Defence Science Journal, Vol. 67, No. 4, July 2017, pp. 465-475.
5. Marcio dos Santos Gomes, Armando Morado Ferreira, 'Gun Turret Modelling and Control', ABCM Symposium Series in Mechatronics - Vol. 2 - pp. 60-67.
6. Fernando G. Martins, 'Tuning PID Controllers using the ITAE Criterion', Int. J. Engng Ed. Vol. 21, No. 5, pp. 867-873, 2005.