



# Complementor competitive advantage: A framework for strategic decisions

Javier Cenamor

Lund University, Department of Business Administration & CIRCLE, S220 07 Lund, Sweden

## ARTICLE INFO

### Keywords:

Complementors  
Platform ecosystems  
Network value  
Platform owners  
End users

## ABSTRACT

Platform ecosystems include complementary product markets that are creating unprecedented business opportunities. Competition within complementary product markets is increasingly intense and fast-changing, and this leads to increased complexity in designing strategies to gain competitive advantage. Prior literature has extensively analyzed the key drivers of platform adoption by end users. Recent research is highlighting the relevance of complementors as critical ecosystem agents that have some strategic freedom. However, current insights into complementors still provide a limited and fragmented explanation of their competitive advantages. This conceptual paper examines current research on platform ecosystems, open innovation and market-based standardization, and analyzes complementor strategic decisions aimed at building a competitive advantage. Our framework contributes to the literature by providing a complementor-centered approach and suggesting a set of propositions that may guide future research. Future studies may extend the insights into the competitive and corporate strategies of complementors in platform ecosystems.

## 1. Introduction

The emergence of digital platform ecosystems is making the role of complementors increasingly relevant (Inoue, 2019; Parker, Van Alstyne, & Jiang, 2017). Platform ecosystems are based on modular technologies that enable supermodular complementarities both in production and in consumption (Jacobides, Cennamo, & Gawer, 2018). For example, Android complementors can identify and resolve operating system bugs, and offer a wide variety of features to end users through a large portfolio of apps. In this respect, platform ecosystem innovation relies on building a network of external parties, known as complementors, which create value on the platform (Bogers et al., 2017). The platform ecosystem approach has consequently facilitated the emergence of new and profitable complementary product markets, such as the mobile apps market, a massive market which generates more than 70 billion dollars worldwide (Statista, 2018). Besides profits, the growth of platform ecosystems also entails fierce competition, and this makes it impossible for the majority of firms to build and sustain a competitive advantage (Cusumano, Gawer, & Yoffie, 2019b; Kapoor & Agarwal, 2017).

The literature has extensively analyzed the sources of competitive advantage in platform ecosystems from different perspectives (McIntyre, Srinivasan, & Chintakananda, 2020). Research into market-based standardization has traditionally explained the competitive advantage of a technology by highlighting the support of different stakeholders (Galagher, 2012; van de Kaa, van den Ende, de Vries, & van Heck, 2011).

Specifically, technology dominance in standard battles depends on boosting network effects by attracting adopters (Katz & Shapiro, 1986, 1994). Thus, network value represents a key driver of technology adoption. Subsequently, research on platforms has highlighted the fact that different agents depend on and affect each other (de Reuver, Sørensen, & Basole, 2018; Wan, Cenamor, Parker, & Van Alstyne, 2017). In this respect, different research streams on ecosystem have analyzed how actors organized around a firm, an innovation, and a platform (i.e. business, innovation, and platform ecosystems, respectively) (Jacobides et al., 2018). The platform ecosystem literature has identified interdependencies among three different type of agents: platform owners, complementors and end users (Cennamo, 2019; Eisenmann, Parker, & Van Alstyne, 2006; Gawer, 2014; Thomas, Autio, & Gann, 2014; Tiwana, 2014). An important part of the research on platform ecosystems has focused on how platform owners attract a large installed base of end users and complementors, in order to boost network effects and hence influence platform adoption (Gretz, 2010; McIntyre & Srinivasan, 2017; Molina-Castillo, Munuera-Alemán, & Calantone, 2011; Schrieck, Wiese, & Krcmar, 2016; Zhu & Iansiti, 2012). In sum, the interdependencies among ecosystem agents are a key source of competitive advantage for the platform. However, a platform-centered approach usually overlooks the complexity of complementor competitive advantage.

Emerging research into innovation and platform ecosystems defends the uniqueness of complementary product markets (Zhu & Liu, 2018).

E-mail address: [javier.cenamor@fek.lu.se](mailto:javier.cenamor@fek.lu.se).

<https://doi.org/10.1016/j.jbusres.2020.09.016>

Received 27 September 2019; Received in revised form 7 September 2020; Accepted 8 September 2020

Available online 18 September 2020

0148-2963/© 2020 Elsevier Inc. All rights reserved.

Specifically, platform ecosystems have leveraged complementor unique sources of competitive advantage by creating and sharing technological architectures. First, complementors are usually considered to have less formal, flatter and more flexible organizational structures than large platform owners. Their relatively more flexible organizations enable complementors to make decisions quicker, which makes their innovation processes more agile than platform owners'. Second, the literature indicates that complementors have a higher degree of radical innovativeness than platform owners (Jugend et al., 2018). Specifically, platform owners frequently aim to build a solid position in their current markets, and hence they choose incremental innovations (Forés & Camisón, 2016). Finally, research shows that complementors have a preference for fluid innovation activities, including networking and informal knowledge sourcing (Dahlander & Gann, 2010). Thus, complementary product markets are an especially fruitful context for massive innovation and, as critical sources of value creation, represent a topic that is relevant to platform ecosystem research (Zhu & Liu, 2018).

The innovation benefits of platform ecosystems are based on the freedom of complementors to provide their products. This implies that platform owners must leave complementors some space for value creation and capture (Parker et al., 2017). Although more or less governed by platform owners, complementary product markets have a certain margin for strategic management (Wen & Zhu, 2019). However, the lack of a coherent understanding of platform ecosystem dynamics, together with the pressure of working in highly dynamic environments, usually result in unclear choices for many complementors (de Reuver et al., 2018; Ozalp & Kretschmer, 2018; Wang & Shaver, 2014). In filling this gap, this article examines current insights into complementor competitive advantage and proposes critical lines for further research on the key drivers affecting the strategic management of complementary products. Specifically, we applied the triangular structure of interdependencies within platform ecosystems (Parker, Van Alstyne, & Choudary, 2016) to classify the strategic decisions by complementors related to end users, platform owners and other complementors. This paper contributes to the literature on platform ecosystems (Cusumano, Gawer, & Yoffie, 2019a; Jacobides et al., 2018), open innovation (Bogers et al., 2017; Eckhardt, Ciuchta, & Carpenter, 2018) and market-based standardization (Shin, Kim, & Hwang, 2015; van de Kaa et al., 2011) by providing a holistic framework for the strategic decisions complementors need to take in order to build a competitive advantage in platform ecosystems.

The paper is structured as follows. The next section reviews the theoretical background on platform ecosystems. The paper then examines the current insights into the drivers of platform adoption and proposes complementor strategic decisions to build a competitive advantage. Finally, the paper ends with a discussion of the principal insights and some lines for future research.

## 2. Theoretical background

Platform ecosystems are modular architectures that consist of a core set of building blocks, known as the platform, and a set of replaceable components that extend its features, known as complementary products (Cusumano et al., 2019a; Tiwana, 2014). The core function of the platform within the technological architecture has led a significant number of studies to focus on platform adoption. In this respect, studies in market-based standardization have extensively examined the drivers of market dominance by different technologies (den Hartigh, Ortt, van de Kaa, & Stolwijk, 2016; Gallagher, 2012; Katz & Shapiro, 1986; Schilling, 2003; Shin et al., 2015; Suárez, 2004; van de Kaa et al., 2011, 2018; van de Kaa & de Vries, 2015; Verdegem & De Marez, 2011). Specifically, technological superiority, interface compatibility, availability of complementary goods, stakeholder support and network effects can all contribute to explaining the victories that have been won in standard battles. In this respect, the complementary products are usually considered as a means to obtain the main end, which is adoption of the technology.

The modular nature of these platforms facilitates a distributed approach to innovation that involves the platform owners and a large number of heterogeneous complementors (Baldwin & Woodard, 2009; Bogers et al., 2017; Schilling, 1999, 2000). In fact, interdependencies in platform ecosystems follow a triangular structure where platform owners facilitate interactions between end users and complementors through the access to their platforms (Parker et al., 2016), as represented in Fig. 1. Specifically, compared to other types of ecosystems and platforms, platform ecosystems are characterized by supermodular complementarities in production and in consumption (Jacobides et al., 2018). For example, game developers enhance the value proposition of a video console, and the end users obtain a higher value when they can play different games on their consoles (Cenamor, Usero, & Fernández, 2013). In this context, the platform owners play the role of platform ecosystem architects and innovation orchestrators (Boudreau, 2017). This central role of the platform owners explains the emphasis the literature places on this type of agent. In other words, the complementors are viewed as dependent agents that react rationally to the strategies of the platform owners. Thus, the literature has extensively examined the strategies employed by platform owners attempting to ensure the adoption of their platforms.

The literature on platform ecosystems has examined how a platform owner can strategically manage the interdependencies among different agents in order to build a competitive advantage for its platform. These agents are the end users, complementors and rival platform owners (Cusumano et al., 2019a; Eisenmann et al., 2006; Thomas et al., 2014). First, platforms have extended the functionalities of traditional products by enabling interactions with other ecosystem agents. In this respect, end users demand from the platform owners different value propositions, and these may be driven by the quality of the platform and its installed base (Zhu & Iansiti, 2012). Second, platform owners have established a new organizational system that lies in the 'middle ground' between the traditional duality of hierarchy and market (Jacobides et al., 2018; McIntyre, Srinivasan, Afuah, et al., 2020). In this *semi-regulated* context, it is the platform owners who define the general rules governing the relationships with their complementors (Boudreau, 2017). For example, platform owners design the openness of the platforms, which are typically either tightly or loosely coupled (Parker & Van Alstyne, 2018). Finally, the interdependent nature of platform ecosystems implies that complementors are also significantly affected by their peers (Srinivasan & Venkatraman, 2018). In this interdependent context, platform owners try to take advantage of the relationships among complementors by promoting collaborative approaches and by triggering individual competition (Boudreau & Lakhani, 2009).

Recent research defends the need to move toward a more specific analysis of complementors. Traditionally, complementors have implicitly been viewed as a relatively homogeneous group of firms that react as a whole to platform owners' decisions. However, recent research shows that the strategic dynamics within complementary product markets are complex, due to the variety of different complementors and the speed at which they change (McIntyre et al., 2020; Ozalp & Kretschmer, 2018). In fact, the intensity of the competition and the pressure from the

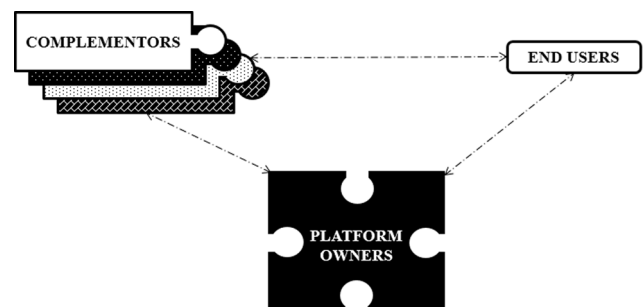

Fig. 1. Triangular structure of interdependencies in platform ecosystems.

platform owners represent important challenges for complementors as platforms mature (Rietveld, Ploog, & Nieborg, 2020). Thus, the understanding of complementor strategies is becoming a critical topic in platform ecosystems (Wen & Zhu, 2019).

Complementors make strategic decisions that affect the complementary product markets and hence the whole ecosystem (Hilbolling, Berends, Deken, & Tuertscher, 2019; Inoue, 2019; Wang & Miller, 2019). Some studies provide diverse insights into the outcomes of the complementor strategies (Altman, 2017; Benlian, Hilkert, & Hess, 2015; Foerderer, Kude, Mithas, & Heinzl, 2018; Kude, Dibbern, & Heinzl, 2012). In this respect, recent studies examine different sources of complementor competitive advantage by analyzing the traditional drivers of platform adoption, i.e. quality and installed base (Healey & Moe, 2016; Ozalp, Cennamo, & Gawer, 2018; Rietveld & Eggers, 2018; Yi, Lee, & Kim, 2019). However, the insights are still fragmented as they originate from empirical studies of different technological contexts. These contexts include mobile payment (Kazan, Tan, Lim, Sørensen, & Damsgaard, 2018; Ondrus, Gannamaneni, & Lyytinen, 2015; Ozcan & Santos, 2015; Rukanova, de Reuver, Henningsson, Nikayin, & Tan, 2019), apps (Karjaluo, Shaikh, Saarijärvi, & Saraniemi, 2019; Z. Zhao & Balagué, 2015; Zhou & Song, 2018), the internet of things (Saarikko, Westergren, & Blomquist, 2017) and video games (Choi, Ko, Medlin, & Chen, 2018; Marchand, 2016). In this respect, when a theory is emerging, conceptual approaches are necessary to connect the findings from an increasingly dispersed set of quantitative papers (Tourish, 2019). Thus, besides the attempts to build a theory of platform ecosystems (Gawer, 2014; Jacobides et al., 2018; Thomas et al., 2014), there is still a need for a theoretical framework for the study of complementors that may serve as a solid basis for future research developments.

This paper examines the strategic choices by complementors aimed at developing sustainable competitive advantages. This paper extends the current insights into the strategic management of platform adoption to explain complementor competitive advantage. The sections below discuss the strategic decisions by complementors related to the value proposition to end users (standalone and network value), the relationship with the platform owners (bi-lateral dependencies and multi-homing synergies) and with other complementors (co-opetitive networks and differentiated offering). Due to the dynamism of platform ecosystems, the paper examines the evolution of the different strategic choices and of complementor competitive advantage as a platform matures. Specifically, the technological, relational and market-related changes are considered in analyzing the platform maturity.

### 3. Complementor interdependencies with end users

The literature on platform battles has traditionally distinguished between two types of value, i.e. the stand-alone value, also known as quality, and the network value, commonly linked to the installed base (Davis, 1989; Katz & Shapiro, 1986). Specifically, the stand-alone value refers to the features used in the absence of other end users, and the network value is derived from the interactions with a set of members who form an installed base (McIntyre & Subramaniam, 2009). One traditional example of stand-alone value is the first PCs, whose main features were processing and storing individual information more efficiently than paper-based options such as spreadsheets for household finance (Cusumano et al., 2019a). A popular example of network-value technology is the landline telephone, whose main feature is enabling long-distance communication between different people (Afuah, 2013).

Platform owners seek to enhance platform adoption by providing different combinations of stand-alone and network value to their end users (McIntyre & Chintakananda, 2014). In this respect, platform owners aim for high-quality complementary products offering high network value, because they typically have disproportionately large effects on platform adoption (Binken & Stremersch, 2009; H. Song, Jung, & Cho, 2017). Current insights indicate that these effects vary with platform maturity due to changes in network intensity (Zhu &

Iansiti, 2012). At one extreme, those markets in which network intensity is still low are generally driven by technical quality (Gretz, 2010). This means that, when end users are deciding to adopt a platform, they focus on the stand-alone features offered by that platform. This leads to multiple platforms and relatively stable competition. In contrast, as a platform matures, its network value becomes increasingly relevant for end users, and small advantages can result in one platform becoming dominant (McIntyre & Chintakananda, 2014). Specifically, network value can exert a great influence on platform adoption (Molina-Castillo et al., 2011). This implies that a complementary product having a large installed base positively affects platform adoption (Cenamor et al., 2013; Gallagher, 2012). In sum, as a platform matures, the network value provided by that platform becomes increasingly important to its competitive advantage.

Recent research has extended current insights into stand-alone and network value and platform adoption, to explain the performance of complementary products (Marchand, 2016; Ozalp et al., 2018; Rietveld & Eggers, 2018). Specifically, high quality platforms can represent a source of competitive advantage for their complementors. This means that more advanced platforms offer new opportunities to complementors to commit to, and invest in, to satisfy early adopters' needs (Cennamo, Ozalp, & Kretschmer, 2018). Specifically, complementors can use the stand-alone value of their complementary products to differentiate their value proposition and to build a competitive advantage based on quality. This is especially relevant at the early stages of platforms that push the technological frontiers significantly forward (Claussen, Essling, & Kretschmer, 2015). Early users expect complementors to provide a portfolio of high-quality complementary products that leverage the features offered by the platform. In fact, many complementors lack both the resources and the incentives to fully exploit the potential features of a complex platform, and this may lead to complementary products of relatively lower quality (Kapoor & Agarwal, 2017; Ozalp et al., 2018). As a platform matures, the audience becomes less technologically-demanding and more heterogeneous and the competition becomes more intense (Rietveld & Eggers, 2018). In this context, building and sustaining a competitive advantage based on stand-alone value is more challenging. Thus, we propose:

*Proposition 1: A complementary product's stand-alone value will represent a source of complementor competitive advantage that becomes less significant as the platform ecosystem matures*

Recent research has also explained that the size of the platform's installed base may have a significant influence on the performance of its complementary products (Marchand, 2016; Yi et al., 2019). In this respect, platforms with large installed bases attract many complementors, which makes it harder for each complementor to exploit the network effects. In fact, compared to their impact on platform adoption, network effects exacerbate the spread and decay of complementary products, leading to high peaks and steep drops (Yi et al., 2019). As a platform matures, a larger installed base of end users for a complementary product provides new end users with positive word of mouth and gives the product improved visibility through high positions in market rankings. In this respect, complementors can leverage the network value of their complementary products by encouraging direct interactions with other users and facilitating information exchange about ways to enhance the complementary product's value, such as tutorials and tips (Marchand, 2016). Thus, complementors can increasingly maximize the network value of their products by developing features that involve several users and hosting online and offline forums for networking, including blogs and hackathons. In sum, both the stand-alone value and the network value of a complementary product may represent key critical sources of complementor competitive advantage that can become critical due to the network effects. Thus, we propose:

*Proposition 2: A complementary product's network value will represent a source of complementor competitive advantage that becomes more significant as the platform ecosystem matures*

#### 4. Complementor interdependencies with platform owners

Platform ecosystems are challenging the traditional rules of innovation management by proposing a unique relationship between the platform owners and their complementors (Economides & Katsamakas, 2006; Rochet & Tirole, 2003). Specifically, platform ecosystems are organizational structures that – in terms of decision-making – involve more companies than hierarchical approaches, while demanding a higher degree of coordination than markets (Jacobides et al., 2018). In this respect, the mechanisms for ecosystem governance entail allocating decision rights and aligning complementor incentives (Miric, Boudreau, & Jeppesen, 2019; Saadatmand, Lindgren, & Schultze, 2019). This semi-regulated nature allows platform owners to share the technological, strategic and network decisions with networks of complementors (McIntyre, Srinivasan, Afuah, et al., 2020). This sharing may be centralized and closed, or in a decentralized, open mode (den Hartigh et al., 2016; Ghazawneh & Henfridsson, 2015). For example, Apple chose a centralized mode for competing against IBM who, in contrast, opted for decentralized mode in the early personal computer industry. In platform ecosystems, the platform owner's control guarantees the coherence of the ecosystem, while the complementor's autonomy enables the wide variety and evolvability of these ecosystems (Wareham, Fox, & Cano Giner, 2014).

Platform ecosystems are based on setting the innovation locus outside the firm's boundaries, which pushes platform owners to share more knowledge and resources than firms in traditional industries (Parker et al., 2017). However, openness is not usually total, and platform owners advisedly keep critical information and tasks for themselves (Parker & Van Alstyne, 2018). In fact, platform owners hold a superior position that allows them to collect information on the intermediated interactions between complementors and users (Eckhardt et al., 2018). These information asymmetries increase uncertainty, and hence may hinder innovation by complementors within the ecosystem (Cusumano, 2010). In fact, if complementors are able to successfully launch a complementary product for the platform, the platform owner may have incentives to integrate it as a core component of the platform or to acquire the complementor, in order to exploit the product and thus avoid having a potentially strong competitor at the platform level (Karhu, Gustafsson, & Lyytinen, 2018; Wen & Zhu, 2019; Zhu & Liu, 2018).

Platform owners not only exploit complementors, but also support them in several different ways. With respect to platform owners entering the complementary product markets, recent research observes non-significant reductions in innovation on the part of the complementors (Foerderer et al., 2018; Wen & Zhu, 2019). In fact, complementors tend to shift their strategic goals toward other complementary product categories. These findings indicate that platform owners' strategic movements in the complementary product market may be interpreted as a sign for future development paths to be taken by complementors. Moreover, besides providing technological support (Alexy, West, Klapper, & Reitzig, 2018), a platform owner usually acts as a powerful ally that offers special protection against external attacks (Bagheri, Minin, Paraboschi, & Piccaluga, 2016). Specifically, platform owners use their legal and market resources on behalf of their complementors when competitors threaten the whole ecosystem, a significant number of small complementors, or key complementors. The fact that platform owners have a special relationship with some complementors challenges the implicit assumption of standardized multilateral relationships between platform owners and complementors (Jacobides et al., 2018; Wareham et al., 2014).

As part of inter-organizational networks, platform owners and some complementors can develop specific bi-lateral dependencies in addition to the ecosystem's general rules (Shipilov & Gawer, 2019). Specifically, complementors can allocate efforts to build mutual trust that facilitates improved information exchange and motivates them to provide support to each other in case of attacks by rivals. In this respect, complementor

support for a new platform in its initial launch can be interpreted by the platform owners as a sign of commitment to the relationship (J. Song, Baker, Wang, Choi, & Bhattacharjee, 2018; Srinivasan & Venkatraman, 2018). In fact, mutual trust between platform owners and complementors stimulates investment in new technologies (Kapoor & Lee, 2013) and hence, differentiated complementary products. Given the intense competition in mature ecosystems, critical information on the complementary product market and special support from platform owners can reinforce complementor competitive advantage. We, therefore, propose:

*Proposition 3: Bi-lateral dependencies will represent a source of complementor competitive advantage that becomes more significant as the platform ecosystem matures*

The decisions taken by other platform owners have a critical impact in the evolution of a platform's adoption (Kazan et al., 2018; Zhu & Iansiti, 2012). Specifically, rival platform owners can leverage the resources that have been made available as a result of the open innovation approach and then rapidly erode the competitive advantage of a competing platform (Karhu & Ritala, 2020). Platform owners have traditionally used exclusive contracts that forbid multi-homing, in order to differentiate their platform ecosystem by locking in their affiliated agents, especially complementors (Armstrong & Wright, 2007). Exclusivity of complementary products prevents the competing platform owners taking advantage of their complementors (Gallagher, 2012), but it slows down platform adoption (Binken & Stremersch, 2009). In fact, those platform owners that aim to maximize the benefits of both a wide variety of complementary products together with a high degree of control may end up with a platform that performs worse (Cennamo & Santalo, 2013). Thus, although many platform owners aim to force ecosystem agents to choose only their platforms, technological battles evolve into market-based (de facto) standardization (Shin et al., 2015; van de Kaa et al., 2011).

Complementors have incentives to interact with the end users of different platforms (Hyrynsalmi, Suominen, & Mäntymäki, 2016). For example, exclusive contracts between app developers and mobile platform owners are rare, so multi-homing is common among app developers. Complementors design growth strategies to leverage the network effects of a larger installed base by adapting their current products to new platform ecosystems (Landsman & Stremersch, 2011). Moreover, a broader scope involving several platforms can be critical for complementors aiming to avoid the problems of a strong embeddedness in one platform (Srinivasan & Venkatraman, 2018). In this respect, many complementors maintain relationships with several platform owners as a way of preserving bargaining power (Wang & Miller, 2019). However, multi-homing may lead complementors to offer complementary products of a lower quality (Cennamo et al., 2018). Specifically, multi-homing implies adapting complementary products to several platform ecosystems, which in turn requires specific technological, governance and organizational resources (Claussen, Kretschmer, & Mayrhofer, 2013; Kapoor & Agarwal, 2017). These adaptations are especially relevant when the existing platforms are significantly different in terms technological sophistication or maturity (Claussen et al., 2015). In this respect, interdependencies in platform ecosystems make growth strategies especially complex, and unfocused strategies may hamper complementor competitive advantage (Tavalaie & Cennamo, 2020). In sum, complementors can build a competitive advantage on multi-homing when they can exploit the synergies between platform ecosystems. Thus, we propose:

*Proposition 4: Multi-homing synergies will represent a source of complementor competitive advantage that becomes more significant as the platform ecosystem matures*

#### 5. Complementor interdependencies with other complementors

Interdependencies in platform ecosystems also refer to same-side interactions, including the relationships among complementors (Wan

et al., 2017). The literature has analyzed how platform sponsors design ecosystems that encourage complementors to co-create value (Boudreau, 2017). Specifically, platform owners facilitate interactions, lower the entry barriers to new markets, and promote a scaled-up collaborative approach (Nambisan, Siegel, & Kenney, 2018; Srinivasan & Venkatraman, 2018; Zhu & Liu, 2018). Platform owners enable the inflows and outflows of knowledge through their technological architectures and organizational governance (Thomas et al., 2014). In this respect, platform owners lead a culture of sharing resources and risks to leverage the competitive advantage of each complementor (Alexy et al., 2018; Jacobides et al., 2018). This implies, for example, that complementors can exploit standardized data collection and analysis on a larger scale, in order to develop more advanced products (Huang, Henfridsson, Liu, & Newell, 2017; Yoo, Henfridsson, & Lyytinen, 2010). In fact, this collaborative approach sometimes goes beyond one platform's boundaries and may involve several platform ecosystems (Casadesus-Masanell & Yoffie, 2007). In some cases, several platform owners coordinate efforts to push their limitations forward and develop better versions of their platforms (Ondrus et al., 2015). Thus, platform ecosystems represent a fruitful context for complementor collaboration.

Recent research claims that strategic moves by a complementor are significantly intertwined with the moves made by other complementors (Srinivasan & Venkatraman, 2018). Complementors join collaborating communities because of the peer interactions and the benefits of learning from others. Collaborative communities facilitate the sharing of a multitude of diverse contributions from a wide range of innovators (Kohler, 2018). However, large crowds can hamper decision making and slow down those initiatives that require specific leadership and critical resources if they are to reach the market (Kohler & Chesbrough, 2019; Rukanova et al., 2019). In this respect, building a network of complementors to collaborate with represents a complex challenge for complementors (Shaikh & Levina, 2019). Specifically, selecting partners involves a focus on value creation and open ecosystem considerations, unlike the traditional criteria for alliance partners that highlight value capture and partner-specific aspects. Thus, complementors that are able to develop a co-opetitive network with key complementors can share specific resources and risks, simplify the decision-making process when speed is required and coordinate their aims in order to reach more advanced goals (Shipilov & Gawer, 2019; van de Kaa, Papachristos, & de Bruijn, 2019). These aspects are critical as a platform matures. We, therefore, propose:

**Proposition 5:** *Co-opetitive networks will represent a source of complementor competitive advantage that becomes more significant as the platform ecosystem matures*

Besides the collaborative approach of platform ecosystems, the literature has also examined the competitive dynamics of complementary product markets (Boudreau & Lakhani, 2009). A building block of platform ecosystems is their reliance on complementary products to satisfy a broadly heterogeneous demand (Sun, Rajiv, & Chu, 2016). Complementors make it possible for end users to add and replace complementary products, thus customizing the platform (Garud, Jain, & Tuertscher, 2008). In this respect, platform owners trigger complementors in order to ensure a wide variety of complementary products (Cusumano et al., 2019a), and low entry barriers attract large numbers of complementors (Y. Zhao, von Delft, Morgan-Thomas, & Buck, 2019). Specifically, complementors compete to place their complementary products at the top of the platform rankings (Boudreau & Jeppesen, 2015). In fact, platform owners keep these rankings updated to motivate complementors to continuously invest in innovation processes (Claussen et al., 2013; Yi et al., 2019). Thus, defining a market position that is differentiated from their competitors represents a key challenge for complementors.

Complementors can extend their portfolio to new product categories within the same platform ecosystem (Barlow, Verhaal, & Angus, 2019). The possibility of reusing platform resources enables complementors to focus on leveraging their unique resources (Tiwana, 2014). Although

motivated to provide end users with pioneering products, a large number of complementors rely on the common resources provided by the platform sponsors, and respond to their rival complementors with slightly different versions of the original products (Xue, Song, Rai, Zhang, & Zhao, 2019). For example, platform APIs can lead complementors to app copycatting. In this respect, the market potential and product complexity can motivate complementors to pursue more innovative goals. In fact, complementors offering complex innovations are likely to lead the market, while those offering simple imitation end up out of the market (Y. Zhao et al., 2019). The limited technological knowledge of the new platform among complementors and the homogeneous demand at early stages can facilitate the identification of a unique proposition (Rietveld & Eggers, 2018). Mature platform ecosystems provide complementors with access to a vast audience of end users through mainstream products, and to a "long tail" of smaller groups of end users through niche products (Miric et al., 2019). The competition is then intense because of the large number of competitors that cover a wide range of specific needs (Boudreau, 2012), and identifying uncovered, promising niches is increasingly more difficult. Complementors with a differentiated offering in the market can use their experience to identify non-attractive niches where many rivals are entering and pursue less trendy alternatives (Ozalp & Kretschmer, 2018). In sum, a differentiated offering can enhance a complementor's competitive response to competitors. We, therefore, propose:

**Proposition 6:** *A differentiated offering will represent a source of complementor competitive advantage that becomes more significant as the platform ecosystem matures*

Fig. 2 summarizes the propositions of the paper.

## 6. Discussion and future research agenda

### 6.1. Theoretical implications

Platform ecosystems have become profitable markets that attract an increasingly large number of complementors (Kapoor & Agarwal, 2017). Specifically, platform ecosystems have unlocked unprecedented opportunities for complementors through sharing resources and encouraging open innovation (Bogers et al., 2017; Thomas et al., 2014). This means that complementors compete in platform ecosystems characterized by network effects, semi-regulated structures and collaborative approaches (McIntyre, Srinivasan, Afuah, et al., 2020; McIntyre et al., 2020). In other words, platform ecosystems are built on the idea of third-parties co-creating value with a balance of the guidance of the platform sponsors and the freedom to make their own strategic choices (Wareham et al., 2014). These circumstances offer complementors unprecedented opportunities together with new challenges that increase the complexity of building a competitive advantage (Nambisan et al., 2018; Yi et al., 2019).

The literature on platform ecosystems has traditionally had a platform-centric view that implicitly observes complementors as a means for platform adoption (Cennamo & Santalo, 2013). However, platform ecosystems attract a multitude of complementors that end up with very diverse results (Boudreau, 2012). In fact, many complementors fail to build and/or sustain a competitive advantage in the complementary product markets. Overall, the literature is starting to shift the main focus towards the complementary product markets. The uniqueness of complementary product markets implies that further attention should be paid to complementor strategies and their consequences for their competitive advantage (Wang & Miller, 2019; Wen & Zhu, 2019). In responding to this need, this paper takes the complementor perspective to review traditional drivers of platform adoption, to examine recent insights into complementor strategic decisions and to suggest a set of propositions regarding complementor competitive advantage. Thus, this paper aims to serve as a bridge between the insights regarding platform adoption and the emerging research on complementor competitive advantage.

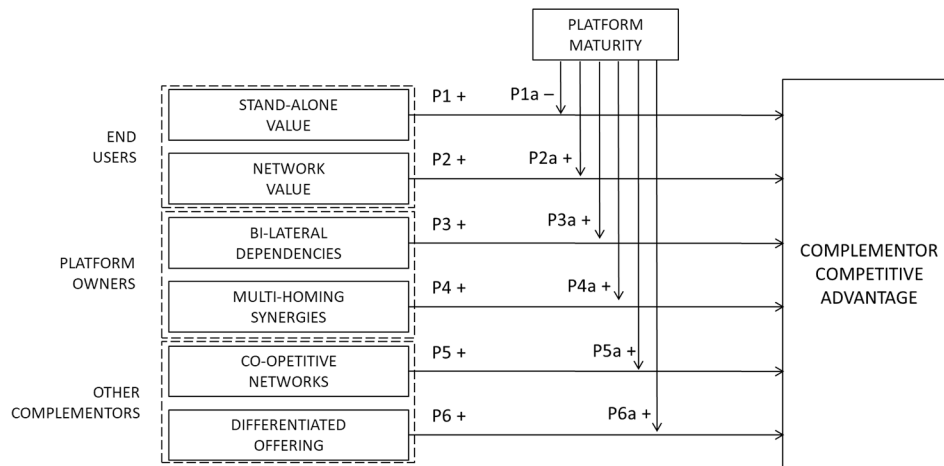

Fig. 2. Complementor strategic decisions and competitive advantage.

Our framework contributes to research on platform ecosystems (Cusumano et al., 2019a; Jacobides et al., 2018), open innovation (Bogers et al., 2017; Eckhardt et al., 2018) and market-based standardization (Shin et al., 2015; van de Kaa et al., 2011) by identifying complementor strategic decisions as related to end users, platform owners, and other complementors. First, our framework examines the strategic decisions related to the value proposition for end users, i.e. stand-alone value and network value. The literature indicates that complementary product quality and installed base may exert a positive effect on platform adoption (H. Song et al., 2017; Zhu & Iansiti, 2012). Our framework proposes that both the stand-alone and the network value of complementary products may be sources of complementor competitive advantage. In fact, the stand-alone value can represent a critical source of competitive advantage for complementors entering a new platform. The complementary products that highlight the novel technological opportunities of the new platform will attract the attention of a large number of the early adopters. For example, some video games aim to use most of the power of the most recently launched generation of a video console (Claussen et al., 2015). Moreover, complementary products that exploit the network value of a large installed base by encouraging social interactions among complementary product users may be highly appreciated by the growing mass of end users on mature platforms. For example, the online game Farmville encouraged interactions among almost unknown Facebook users to get different badges and rewards (Zhu & Iansiti, 2019). Thus, a deeper understanding of the differences in end user value can allow complementors to stress the features that the end users value the most.

Second, this paper explains the strategic decisions related to the relationships with the platform sponsors, i.e. bi-lateral dependencies and multi-homing synergies. The literature has traditionally claimed that platform governance can explain differences in platform adoption (van de Kaa et al., 2019; Wareham et al., 2014). In fact, platform ecosystems are traditionally characterized by standardized, multilateral relationships between platform owners and complementors (Jacobides et al., 2018). Our framework stresses that beyond the general rules complementors may have some strategic margin on their relationship with the platform owners. In this respect, developing bi-lateral dependencies based on trust may enable complementors to enhance the information exchange with platform owners and to assure a mutual support in critical situations, for example under the attack of rivals. Moreover, establishing relationships with several platform owners, i.e. multi-homing, can represent a source of diverse resources and a tool for preserving bargaining power. In this respect, this paper extends recent research on complementor growth strategies (Tavalaei & Cennamo, 2020) by highlighting the relevance of exploiting synergies. Due to the adaptations required by multi-homing, only those complementors exploiting

synergies between ecosystems will be able to sustain a competitive advantage. These sources of complementor competitive advantage will become critical as the platform matures because complementors will then typically face fiercer competition.

Finally, this paper examines the strategic decisions related to the relationships with other complementors, i.e. co-opetitive networks and differentiated offering. The literature has extensively defended the collaborative approach in platform ecosystems from the perspective of the platform owners opening their innovation (Bogers et al., 2017; Nambisan et al., 2018; Srinivasan & Venkatraman, 2018; Zhu & Liu, 2018). In line with recent research (Shipilov & Gawer, 2019), our framework points to the formation of networks of complementors as a source of a competitive advantage. Besides the common pool of platform resources, complementors build their own network of co-opetitors to exchange resources and coordinate ambitious goals. Moreover, complementors are supposed to re-use platform resources to avoid redundancies and to leverage their unique resources. In this respect, our framework suggests that a highly differentiated offering compared to competitors can represent a source of competitive advantage, especially when the market becomes overcrowded of complementary products.

### 6.2. Future research agenda

Platform ecosystems are questioning the established insights in strategic management literature. Recent research is revising the applicability of the literature’s traditional approaches to explaining the outcomes of platform strategies, while suggesting future paths for the strategic management of platform ecosystems (Alexy et al., 2018; McIntyre & Srinivasan, 2017; Nambisan, Zahra, & Luo, 2019). In this respect, this paper proposes the following research agenda on the strategic decisions taken by complementors, from the perspective of their competitive and corporate strategies.

First, the exploitation of economies of scale has been extensively linked to the cost leadership strategy, while differentiation has been related to the unique offerings that are distinct from competitors’ offerings (Porter, 1980). In platform ecosystems, the information-related benefits of digital technologies enable near-zero marginal costs. Moreover, the focus on economies of scale has been shifted towards the demand side as a source of network value (Parker et al., 2016). This explains that attracting a large installed base has become a strategic goal for many platform sponsors that aim to exploit network effects (Eisenmann et al., 2006). In this respect, complementor heterogeneity is critical to attracting end users to platform ecosystems (Boudreau & Jeppesen, 2015; McIntyre, Srinivasan, Afuah, et al., 2020).

This paper contributes to current insights into the topic by proposing different strategic decisions that can explain differences in

complementor competitive advantage. However, there is a lack of understanding of the specific resources, activities and processes that allow complementors to exploit cost and differentiation advantages. For example, experienced complementors can use their market knowledge and brand loyalty to extend the typically-short lifecycle of their complementary products (Marchand, 2016). Thus, future research could add individual complementor characteristics to the analysis of their competitive advantage.

Second, we also suggest a deeper analysis of complementor growth strategies. Traditionally, the literature has explained the benefits of corporate strategies (i.e. diversification, vertical integration and internationalization) by highlighting the synergies between resources that are deployed in different activities (Porter, 1980). Current insights into platform growth defend the unique benefits for platform owners of expanding the boundaries of their platform ecosystems by enveloping or piggybacking other platforms (Eisenmann, Parker, & Van Alstyne, 2011; Karhu & Ritala, 2020), by competing with their complementors (Zhu & Liu, 2018), or by operating in different countries (Nambisan et al., 2019).

As an emerging topic, the analysis of the corporate strategies of platform ecosystem firms needs further development, especially for complementors. Regarding diversification, defining portfolio scope –within the same platform ecosystem and across different platform ecosystems– represents a critical strategic move that may lead to performance improvements (Tavalaei & Cennamo, 2020). However, it is still unclear how complementors can identify common resources and capabilities that can be deployed in offering a broader portfolio. On one hand, the competitive pressure within the market makes it difficult to find attractive niches for end users that allow complementors to exploit synergies with their current resources. On the other hand, the attempts by platform owners to differentiate their platforms make taking advantage of similar activities and processes a very complex task. Thus, future research could explore how complementors can leverage a diversification strategy in platform ecosystems.

Analyzing integration strategies is especially complex, due to the triangular nature of platform ecosystems –as shown in Fig. 1. Complementors are neither suppliers that sell components to platform owners, nor customers that buy inputs for their products. In this respect, platform sponsors that launch their own complementary products co-opt with the complementors. Current research has provided some explanations of the general reactions of complementors to the entry of platform sponsors into the complementary product market (Wen & Zhu, 2019; Zhu & Liu, 2018). However, our understanding of how complementors' different strategic responses affect their performance is still limited. In fact, some complementors are able to transform their complementary products into *nested* platforms (Tiwana, 2014). Future research may explore the different paths, strategic choices, and critical resources required to accomplish this transformation.

Regarding internationalization, the modular nature of platform ecosystems together with their information-based advantages allow many platform sponsors to operate on a global scale. In this respect, many firms in platform ecosystems are created with a global scope from the start (Brouthers, Geisser, & Rothlauf, 2016). Moreover, the location of the complementors can explain their access to particular resources that may leverage their competitive advantage. In fact, some platform sponsors extend the diversity of their portfolios by facilitating the entry of SMEs into foreign markets through their platforms (Jin & Hurd, 2018). Since platform ecosystems are rapidly spreading worldwide, academic insights are still at an early stage (Nambisan et al., 2019). This paper therefore points out the potential opportunities for future research into complementors operating in different countries. Specifically, we suggest a further exploration of complementors' approaches to international markets (i.e. standardization versus adaptation) and their paths to internationalization.

Finally, future studies could strengthen the analysis of the dynamics of platform ecosystems by simultaneously analyzing several actors and

also by broadening the notion of maturity. Ecosystem agents adapt their strategic decisions based on the current and expected movements of other agents (Cabral, 2019; de Reuver et al., 2018). The literature on platform dynamics has extensively discussed several stages of the platform lifecycle (Teeco, 2017). However, many small complementors may face problems in identifying the transition between the middle stages of this lifecycle and in forecasting the outcome of new platform generations.

Complementors that can identify potential opportunities typically exploit multi-homing synergies via versions of their complementary products for several platforms over several generations. This means that the maturity of these complementary products is not limited to the lifecycle of one platform. In other words, complementary product maturity may reflect a whole lifecycle of a complementary product that includes several versions for platforms in the same and in subsequent generations. In this respect, future research may integrate the strategic decisions of platform owners and complementors into a dynamic framework. Specifically, future empirical analyses may examine longitudinal data by observing the different actions and reactions of different ecosystem agents, both platform owners and complementors, and their competitive advantages over both the short and long term. Thus, a holistic view of the strategic dynamics of the different ecosystem agents is critical to building a solid theoretical background for platform ecosystems.

## Declaration of Competing Interest

The authors declare that they have no known competing financial interests or personal relationships that could have appeared to influence the work reported in this paper.

## Acknowledgements

This work was supported by The Kamprad Family Foundation for Entrepreneurship, Research & Charity.

## References

- Afuah, A. (2013). Are network effects really all about size? The role of structure and conduct. *Strategic Management Journal*, 34(3), 257–273. <https://doi.org/10.1002/smj.2013>.
- Alexy, O., West, J., Klapper, H., & Reitzig, M. (2018). Surrendering control to gain advantage: Reconciling openness and the resource-based view of the firm. *Strategic Management Journal*, 39(6), 1704–1727. <https://doi.org/10.1002/smj.2706>.
- Altman, E. J. (2017). Dependencies, complementor evolution, response strategies: joining a multi-sided platform ecosystem. *Academy of Management Proceedings*, 2017(1), 15484. <https://doi.org/10.5465/AMBPP.2017.15484abstract>.
- Armstrong, M., & Wright, J. (2007). Two-sided markets, competitive bottlenecks and exclusive contracts. *Economic Theory*, 32(2), 353–380. <https://doi.org/10.1007/s00199-006-0114-6>.
- Bagheri, S. K., Minin, A. D., Paraboschi, A., & Piccaluga, A. (2016). It's not about being generous: Platform leaders and patent shelters. *Research-Technology Management*, 59(2), 28–35. <https://doi.org/10.1080/08956308.2015.1137195>.
- Baldwin, C. Y., & Woodard, C. J. (2009). The architecture of platforms: a unified view. In A. Gawer (Ed.), *Platforms, Markets and Innovation* (Vol. 1–Book, Section, pp. 19–44). Edward Elgar Publishing.
- Barlow, M. A., Verhaal, J. C., & Angus, R. W. (2019). Optimal distinctiveness, strategic categorization, and product market entry on the Google Play app platform. *Strategic Management Journal*, smj.3019. <https://doi.org/10.1002/smj.3019>.
- Benlian, A., Hilker, D., & Hess, T. (2015). How open is this platform? The meaning and measurement of platform openness from the complementors' perspective. *Journal of Information Technology*, 30(3), 209–228. <https://doi.org/10.1057/jit.2015.6>.
- Binken, J. L., & Stremersch, S. (2009). The effect of superstar software on hardware sales in system markets. *Journal of Marketing*, 73, 88–104.
- Bogers, M., Zobel, A.-K., Afuah, A., Almirall, E., Brunswicker, S., Dahlander, L., ... Ter Wal, A. L. J. (2017). The open innovation research landscape: Established perspectives and emerging themes across different levels of analysis. *Industry and Innovation*, 24(1), 8–40. <https://doi.org/10.1080/13662716.2016.1240068>.
- Boudreau, K. J. (2012). Let a thousand flowers bloom? An early look at large numbers of software app developers and patterns of innovation. *Organization Science*, 23(5), 1409–1427. <https://doi.org/10.1287/orsc.1110.0678>.
- Boudreau, K. J. (2017). Platform boundary choices & governance: Opening-up while still coordinating and orchestrating. In J. Furman, A. Gawer, B. S. Silverman, & S. Stern

- (Eds.), *Advances in strategic management* (pp. 227–297). Emerald Publishing Limited. <https://doi.org/10.1108/S0742-332220170000037009>.
- Boudreau, K. J., & Jeppesen, L. B. (2015). Unpaid crowd complementors: The platform network effect mirage. *Strategic Management Journal*, 36(12), 1761–1777. <https://doi.org/10.1002/smj.2324>.
- Boudreau, K. J., & Lakhani, K. R. (2009). How to manage outside innovation. *Sloan Management Review*, 50(4), 69–76.
- Brouthers, K. D., Geisser, K. D., & Rothlauf, F. (2016). Explaining the internationalization of ibusiness firms. *Journal of International Business Studies*, 47(5), 513–534. <https://doi.org/10.1057/jibs.2015.20>.
- Cabral, L. (2019). Towards a theory of platform dynamics. *Journal of Economics & Management Strategy*. <https://doi.org/10.1111/jems.12312>.
- Casadesus-Masanell, R., & Yoffie, D. B. (2007). Wintel: Cooperation and conflict. *Management Science*, 53(4), 584–598.
- Cenamor, J., Usero, B., & Fernández, Z. (2013). The role of complementary products on platform adoption: Evidence from the video console market. *Technovation*, 33(12), 405–416. <https://doi.org/10.1016/j.technovation.2013.06.007>.
- Cenamo, C. (2019). Competing in digital markets: a platform-based perspective. Academy of Management Perspectives, amp.2016.0048. <https://doi.org/10.5465/amp.2016.0048>.
- Cenamo, C., Ozalp, H., & Kretschmer, T. (2018). Platform architecture and quality trade-offs of multihoming complements. *Information Systems Research*, 29(2), 461–478. <https://doi.org/10.1287/isre.2018.0779>.
- Cenamo, C., & Santalo, J. (2013). Platform competition: Strategic trade-offs in platform markets. *Strategic Management Journal*, 34(11), 1331–1350. <https://doi.org/10.1002/smj.2066>.
- Choi, H. S., Ko, M. S., Medlin, D., & Chen, C. (2018). The effect of intrinsic and extrinsic quality cues of digital video games on sales: An empirical investigation. *Decision Support Systems*, 106, 86–96. <https://doi.org/10.1016/j.dss.2017.12.005>.
- Claussen, J., Essling, C., & Kretschmer, T. (2015). When less can be more – Setting technology levels in complementary goods markets. *Research Policy*, 44(2), 328–339. <https://doi.org/10.1016/j.respol.2014.10.005>.
- Claussen, J., Kretschmer, T., & Mayrhofer, P. (2013). The effects of rewarding user engagement: The case of Facebook apps. *Information Systems Research*, 24(1), 186–200. <https://doi.org/10.1287/isre.1120.0467>.
- Cusumano, M. A. (2010). *Staying Power: Six enduring principles for managing strategy and innovation in an uncertain world*. Oxford University Press.
- Cusumano, M. A., Gawer, A., & Yoffie, D. B. (2019a). The business of platforms: Strategy in the age of digital competition, innovation, and power. *HarperBusiness*.
- Cusumano, M. A., Gawer, A., & Yoffie, D. B. (2019b). How digital platforms have become double-edged swords. *MIT Sloan Management Review*. <https://sloanreview.mit.edu/article/how-digital-platforms-have-become-double-edged-swords/>.
- Dahlander, L., & Gann, D. M. (2010). How open is innovation? *Research Policy*, 39(6), 699–709. <https://doi.org/10.1016/j.respol.2010.01.013>.
- Davis, F. D. (1989). Perceived usefulness, perceived ease of use, and user acceptance of information technology. *MIS Quarterly*, 13(3), 319–340.
- de Reuver, M., Sørensen, C., & Basole, R. C. (2018). The digital platform: A research agenda. *Journal of Information Technology*, 33(2), 124–135. <https://doi.org/10.1057/s41265-016-0033-3>.
- den Hartigh, E., Ortt, J. R., van de Kaa, G., & Stolwijk, C. C. M. (2016). Platform control during battles for market dominance: The case of Apple versus IBM in the early personal computer industry. *Technovation*, 48–49, 4–12. <https://doi.org/10.1016/j.technovation.2015.12.001>.
- Eckhardt, J. T., Ciuchta, M. P., & Carpenter, M. (2018). Open innovation, information, and entrepreneurship within platform ecosystems. *Strategic Entrepreneurship Journal*, 12(3), 369–391. <https://doi.org/10.1002/sej.1298>.
- Economides, N., & Katsamakas, E. (2006). Two-sided competition of proprietary vs. open source technology platforms and the implications for the software industry. *Management Science*, 52(7), 1057–1071.
- Eisenmann, T., Parker, G., & Van Alstyne, M. (2006). Strategies for two-sided markets. *Harvard Business Review*, 84(10), 92–101.
- Eisenmann, T., Parker, G., & Van Alstyne, M. (2011). Platform envelopment. *Strategic Management Journal*, 32(12), 1270–1285. <https://doi.org/10.1002/smj.935>.
- Foerderer, J., Kude, T., Mithas, S., & Heinzl, A. (2018). Does platform owner's entry crowd out innovation? Evidence from Google photos. Information Systems Research. <https://doi.org/10.1287/isre.2018.0787>.
- Forés, B., & Camisón, C. (2016). Does incremental and radical innovation performance depend on different types of knowledge accumulation capabilities and organizational size? *Journal of Business Research*, 69(2), 831–848. <https://doi.org/10.1016/j.jbusres.2015.07.006>.
- Gallagher, S. R. (2012). The battle of the blue laser DVDs: The significance of corporate strategy in standards battles. *Technovation*, 32(2), 90–98. <https://doi.org/10.1016/j.technovation.2011.10.004>.
- Garud, R., Jain, S., & Tuertscher, P. (2008). Incomplete by design and designing for incompleteness. *Organization Studies*, 29(3), 351–371. <https://doi.org/10.1177/0170840607088018>.
- Gawer, A. (2014). Bridging differing perspectives on technological platforms: Toward an integrative framework. *Research Policy*, 43(7), 1239–1249. <https://doi.org/10.1016/j.respol.2014.03.006>.
- Ghazawneh, A., & Henfridsson, O. (2015). A paradigmatic analysis of digital application marketplaces. *Journal of Information Technology*, 30(3), 198–208. <https://doi.org/10.1057/jit.2015.16>.
- Gretz, R. T. (2010). Hardware quality vs. network size in the home video game industry. *Journal of Economic Behavior & Organization*, 76(2), 168–183. <https://doi.org/10.1016/j.jebo.2010.07.007>.
- Healey, J., & Moe, W. W. (2016). The effects of installed base innovativeness and recency on content sales in a platform-mediated market. *International Journal of Research in Marketing*, 33(2), 246–260. <https://doi.org/10.1016/j.ijresmar.2015.07.004>.
- Hilbolling, S., Berends, H., Deken, F., & Tuertscher, P. (2019). Complementors as connectors: Managing open innovation around digital product platforms. *R&D Management*. <https://doi.org/10.1111/radm.12371>.
- Huang, J., Henfridsson, O., Liu, M. J., & Newell, S. (2017). Growing on steroids: Rapidly scaling the user base of digital ventures through digital innovation. *MIS Quarterly*, 41(1), 301–314. <https://doi.org/10.25300/MISQ/2017/41.1.16>.
- Hyrnsalmi, S., Suominen, A., & Mäntymäki, M. (2016). The influence of developer multi-homing on competition between software ecosystems. *Journal of Systems and Software*, 111, 119–127. <https://doi.org/10.1016/j.jss.2015.08.053>.
- Inoue, Y. (2019). Winner-takes-all or co-evolution among platform ecosystems: A look at the competitive and symbiotic actions of complementors. *Sustainability*, 11(3), 726. <https://doi.org/10.3390/su11030726>.
- Jacobides, M. G., Cennamo, C., & Gawer, A. (2018). Towards a theory of ecosystems. *Strategic Management Journal*, 39(8), 2255–2276. <https://doi.org/10.1002/smj.2904>.
- Jin, H., & Hurd, F. (2018). Exploring the impact of digital platforms on SME internationalization: New Zealand SMEs use of the Alibaba platform for Chinese market entry. *Journal of Asia-Pacific Business*, 19(2), 72–95. <https://doi.org/10.1080/10599231.2018.1453743>.
- Jugend, D., Jabbour, C. J. C., Alves Scaliza, J. A., Rocha, R. S., Junior, J. A. G., Latan, H., & Salgado, M. H. (2018). Relationships among open innovation, innovative performance, government support and firm size: Comparing Brazilian firms embracing different levels of radicalism in innovation. *Technovation*, 74–75, 54–65. <https://doi.org/10.1016/j.technovation.2018.02.004>.
- Kapoor, R., & Agarwal, S. (2017). Sustaining superior performance in business ecosystems: Evidence from application software developers in the iOS and android smartphone ecosystems. *Organization Science*, 28(3), 531–551. <https://doi.org/10.1287/orsc.2017.1122>.
- Kapoor, R., & Lee, J. M. (2013). Coordinating and competing in ecosystems: How organizational forms shape new technology investments. *Strategic Management Journal*, 34(3), 274–296. <https://doi.org/10.1002/smj.2010>.
- Karhu, K., Gustafsson, R., & Lyytinen, K. (2018). Exploiting and defending open digital platforms with boundary resources: Android's five platform forks. *Information Systems Research*, 29(2), 479–497. <https://doi.org/10.1287/isre.2018.0786>.
- Karhu, K., & Ritala, P. (2020). Slicing the cake without baking it: Opportunistic platform entry strategies in digital markets. *Long Range Planning*, 101988. <https://doi.org/10.1016/j.lrp.2020.101988>.
- Karjaluoto, H., Shaikh, A. A., Saarijärvi, H., & Saraniemi, S. (2019). How perceived value drives the use of mobile financial services apps. *International Journal of Information Management*, 47, 252–261. <https://doi.org/10.1016/j.ijinfomgt.2018.08.014>.
- Katz, M. L., & Shapiro, C. (1986). Technology adoption in the presence of network externalities. *Journal of Political Economy*, 94, 822–841.
- Katz, M. L., & Shapiro, C. (1994). Systems competition and network effects. *Journal of Economic Perspectives*, 8, 93–115.
- Kazan, E., Tan, C.-W., Lim, E. T. K., Sørensen, C., & Damsgaard, J. (2018). Disentangling digital platform competition: the case of UK mobile payment platforms. *Journal of Management Information Systems*, 35(1), 180–219. <https://doi.org/10.1080/07421222.2018.1440772>.
- Kohler, T. (2018). How to scale crowdsourcing platforms. *California Management Review*, 60(2), 98–121. <https://doi.org/10.1177/0008125617738261>.
- Kohler, T., & Chesbrough, H. (2019). From collaborative community to competitive market: The quest to build a crowdsourcing platform for social innovation. *R&D Management*, 49(3), 356–368. <https://doi.org/10.1111/radm.12372>.
- Kude, T., Dibbern, J., & Heinzl, A. (2012). Why do complementors participate? An analysis of partnership networks in the enterprise software industry. *IEEE Transactions on Engineering Management*, 59(2), 250–265. <https://doi.org/10.1109/TEM.2011.2111421>.
- Landsman, V., & Stremersch, S. (2011). Multihoming in two-sided markets: An empirical inquiry in the video game console industry. *Journal of Marketing*, 75(6), 39–54.
- Marchand, A. (2016). The power of an installed base to combat lifecycle decline: The case of video games. *International Journal of Research in Marketing*, 33(1), 140–154. <https://doi.org/10.1016/j.ijresmar.2015.06.006>.
- McIntyre, D. P., & Chintakananda, A. (2014). Competing in network markets: Can the winner take all? *Business Horizons*, 57(1), 117–125. <https://doi.org/10.1016/j.bushor.2013.09.005>.
- McIntyre, D. P., & Srinivasan, A. (2017). Networks, platforms, and strategy: Emerging views and next steps. *Strategic Management Journal*, 38(1), 141–160. <https://doi.org/10.1002/smj.2596>.
- McIntyre, D. P., Srinivasan, A., Afuah, A., Gawer, A., & Kretschmer, T. (2020). Multi-sided platforms as new organizational forms. *Academy of Management Perspectives*. <https://doi.org/10.5465/amp.2018.0018>.
- McIntyre, D. P., Srinivasan, A., & Chintakananda, A. (2020). The persistence of platforms: The role of network, platform, and complementor attributes. *Long Range Planning*, 101987. <https://doi.org/10.1016/j.lrp.2020.101987>.
- McIntyre, D. P., & Subramaniam, M. (2009). Strategy in network industries: A review and research agenda. *Journal of Management*, 35(6), 1494–1517.
- Miric, M., Boudreau, K. J., & Jeppesen, L. B. (2019). Protecting their digital assets: The use of formal & informal appropriability strategies by App developers. *103738 Research Policy*, 48(8). <https://doi.org/10.1016/j.respol.2019.01.012>.
- Molina-Castillo, F. J., Munuera-Alemán, J. L., & Calantone, R. J. (2011). Product quality and new product performance: The role of network externalities and switching costs. *Journal of Product Innovation Management*, 28(6), 915–929.



- Nambisan, S., Siegel, D., & Kenney, M. (2018). On open innovation, platforms, and entrepreneurship. *Strategic Entrepreneurship Journal*, 12(3), 354–368. <https://doi.org/10.1002/sej.1300>.
- Nambisan, S., Zahra, S. A., & Luo, Y. (2019). Global platforms and ecosystems: Implications for international business theories. *Journal of International Business Studies*, 50(9), 1464–1486. <https://doi.org/10.1057/s41267-019-00262-4>.
- Ondrus, J., Gannamaneni, A., & Lyytinen, K. (2015). The impact of openness on the market potential of multi-sided platforms: A case study of mobile payment platforms. *Journal of Information Technology*, 30(3), 260–275. <https://doi.org/10.1057/jit.2015.7>.
- Ozalp, H., Cennamo, C., & Gawer, A. (2018). Disruption in platform-based ecosystems. *Journal of Management Studies*, 55(7), 1203–1241. <https://doi.org/10.1111/joms.12351>.
- Ozalp, H., & Kretschmer, T. (2018). Follow the crowd or follow the trailblazer? The differential role of firm experience in product entry decisions in the US video game industry. *Journal of Management Studies*. <https://doi.org/10.1111/joms.12389>.
- Ozcan, P., & Santos, F. M. (2015). The market that never was: Turf wars and failed alliances in mobile payments. *Strategic Management Journal*, 36(10), 1486–1512. <https://doi.org/10.1002/smj.2292>.
- Parker, G., & Van Alstyne, M. (2018). Innovation, openness, and platform control. *Management Science*, 64(7), 3015–3032. <https://doi.org/10.1287/mnsc.2017.2757>.
- Parker, G., Van Alstyne, M., & Choudary, S. P. (2016). *Platform revolution: How networked markets are transforming the economy and how to make them work for you (First Edition)*. W. W. Norton & Company.
- Parker, G., Van Alstyne, M., & Jiang, X. (2017). Platform ecosystems: How developers invert the firm. *MIS Quarterly*, 41(1), 255–266. <https://doi.org/10.25300/MISQ/2017/41.1.13>.
- Porter, M. E. (1980). *Competitive strategy: Techniques for analyzing industries and competitors: With a new introduction*. Free Press.
- Rietveld, J., & Eggers, J. P. (2018). Demand heterogeneity in platform markets: Implications for complementors. *Organization Science*, 29(2), 304–322. <https://doi.org/10.1287/orsc.2017.1183>.
- Rietveld, J., Ploog, J. N., & Nieborg, D. B. (2020). The coevolution of platform dominance and governance strategies: effects on complementor performance outcomes. *Academy of Management Discoveries*, amd.2019.0064. <https://doi.org/10.5465/amd.2019.0064>.
- Rochet, J.-C., & Tirole, J. (2003). Platform competition in two-sided markets. *Journal of the European Economic Association*, 1(4), 990–1029. <https://doi.org/10.1162/154247603322493212>.
- Rukanova, B., de Reuver, M., Henningson, S., Nikayin, F., & Tan, Y.-H. (2019). Emergence of collective digital innovations through the process of control point driven network reconfiguration and reframing: The case of mobile payment. *Electronic Markets*. <https://doi.org/10.1007/s12525-019-00352-z>.
- Saadatmand, F., Lindgren, R., & Schultze, U. (2019). Configurations of platform organizations: Implications for complementor engagement, 103770 *Research Policy*, 48(8). <https://doi.org/10.1016/j.respol.2019.03.015>.
- Saarikko, T., Westergren, U. H., & Blomquist, T. (2017). The internet of things: Are you ready for what's coming? *Business Horizons*, 60(5), 667–676. <https://doi.org/10.1016/j.bushor.2017.05.010>.
- Schilling, M. A. (1999). Winning the standards race: Building installed base and the availability of complementary goods. *European Management Journal*, 17(3), 265–274. [https://doi.org/10.1016/S0263-2373\(99\)00005-5](https://doi.org/10.1016/S0263-2373(99)00005-5).
- Schilling, M. A. (2000). Toward a general modular systems theory and its application to interfirm product modularity. *The Academy of Management Review*, 25(2), 312–334. <https://doi.org/10.2307/259016>.
- Schilling, M. A. (2003). Technological leapfrogging: Lessons from the U.S. video game console industry. *California Management Review*, 45(3), 6–32.
- Schrieck, M., Wiesche, M., & Krcmar, H. (2016). Design and governance of platform ecosystems - key concepts and issues for future research. ECIS.
- Shaikh, M., & Levina, N. (2019). Selecting an open innovation community as an alliance partner: Looking for healthy communities and ecosystems, 103766 *Research Policy*, 48(8). <https://doi.org/10.1016/j.respol.2019.03.011>.
- Shin, D.-H., Kim, H., & Hwang, J. (2015). Standardization revisited: A critical literature review on standards and innovation. *Computer Standards & Interfaces*, 38, 152–157. <https://doi.org/10.1016/j.csi.2014.09.002>.
- Shipilov, A., & Gawer, A. (2019). Integrating research on inter-organizational networks and ecosystems. *Academy of Management Annals*, annals.2018.0121. <https://doi.org/10.5465/annals.2018.0121>.
- Song, H., Jung, J., & Cho, D. (2017). Platform competition in the video game console industry: Impacts of software quality and exclusivity on market share. *Journal of Media Economics*, 30(3), 99–120. <https://doi.org/10.1080/08997764.2018.1449750>.
- Song, J., Baker, J., Wang, Y., Choi, H. Y., & Bhattacharjee, A. (2018). Platform adoption by mobile application developers: A multimethodological approach. *Decision Support Systems*, 107, 26–39. <https://doi.org/10.1016/j.dss.2017.12.013>.
- Srinivasan, A., & Venkatraman, N. (2018). Entrepreneurship in digital platforms: A network-centric view. *Strategic Entrepreneurship Journal*, 12(1), 54–71. <https://doi.org/10.1002/sej.1272>.
- Statista. (2018). App stores (did-13112-1).
- Suárez, F. F. (2004). Battles for technological dominance: An integrative framework. *Research Policy*, 33(2), 271–286. <https://doi.org/10.1016/j.respol.2003.07.001>.
- Sun, L., Rajiv, S., & Chu, J. (2016). Beyond the more the merrier: The variety effect and consumer heterogeneity in system markets. *International Journal of Research in Marketing*, 33(2), 261–275. <https://doi.org/10.1016/j.ijresmar.2015.05.010>.
- Tavalaei, M. M., & Cennamo, C. (2020). In search of complementarities within and across platform ecosystems: Complementors' relative standing and performance in mobile apps ecosystems. *Long Range Planning*, 101994. <https://doi.org/10.1016/j.lrp.2020.101994>.
- Teece, D. J. (2017). Dynamic capabilities and (digital) platform lifecycles. In J. Furman, A. Gawer, B. S. Silverman, & S. Stern (Eds.), *Advances in strategic management* (pp. 211–225). Emerald Publishing Limited. <https://doi.org/10.1108/S0742-332220170000037008>.
- Thomas, L. D. W., Autio, E., & Gann, D. M. (2014). Architectural leverage: Putting platforms in context. *Academy of Management Perspectives*, 28(2), 198–219. <https://doi.org/10.5465/amp.2011.0105>.
- Tiwana, A. (2014). *Platform ecosystems: Aligning architecture, governance, and strategy*. Elsevier / Morgan Kaufmann.
- Tourish, D. (2019). The triumph of nonsense in management studies. *Academy of Management Learning & Education*, amle.2019.0255. <https://doi.org/10.5465/amle.2019.0255>.
- van de Kaa, G., & de Vries, H. J. (2015). Factors for winning format battles: A comparative case study. *Technological Forecasting and Social Change*, 91, 222–235. <https://doi.org/10.1016/j.techfore.2014.02.019>.
- van de Kaa, G., Janssen, M., & Rezaei, J. (2018). Standards battles for business-to-government data exchange: Identifying success factors for standard dominance using the Best Worst Method. *Technological Forecasting and Social Change*, 137, 182–189. <https://doi.org/10.1016/j.techfore.2018.07.041>.
- van de Kaa, G., Papachristos, G., & de Bruijn, H. (2019). The governance of platform development processes: A metaphor and a simulation model. *Technological Forecasting and Social Change*, 138, 190–203. <https://doi.org/10.1016/j.techfore.2018.08.021>.
- van de Kaa, G., van den Ende, J., de Vries, H. J., & van Heck, E. (2011). Factors for winning interface format battles: A review and synthesis of the literature. *Technological Forecasting and Social Change*, 78(8), 1397–1411. <https://doi.org/10.1016/j.techfore.2011.03.011>.
- Verdegem, P., & De Marez, L. (2011). Rethinking determinants of ICT acceptance: Towards an integrated and comprehensive overview. *Technovation*, 31(8), 411–423. <https://doi.org/10.1016/j.technovation.2011.02.004>.
- Wan, X., Cenamor, J., Parker, G., & Van Alstyne, M. (2017). Unraveling platform strategies: A review from an organizational ambidexterity perspective. *Sustainability*, 9(5), 734. <https://doi.org/10.3390/su9050734>.
- Wang, R. D., & Miller, C. D. (2019). Complementors' engagement in an ecosystem: A study of publishers' e-book offerings on amazon kindle. *Strategic Management Journal*, smj.3076. <https://doi.org/10.1002/smj.3076>.
- Wang, R. D., & Shaver, J. M. (2014). Competition-driven repositioning: Competition-driven repositioning. *Strategic Management Journal*, 35(11), 1585–1604. <https://doi.org/10.1002/smj.2167>.
- Wareham, J., Fox, P. B., & Cano Giner, J. L. (2014). Technology ecosystem governance. *Organization Science*, 25(4), 1195–1215. <https://doi.org/10.1287/orsc.2014.0895>.
- Wen, W., & Zhu, F. (2019). Threat of platform-owner entry and complementor responses: Evidence from the mobile app market. *Strategic Management Journal*, 40(9), 1336–1367. <https://doi.org/10.1002/smj.3031>.
- Xue, L., Song, P., Rai, A., Zhang, C., & Zhao, X. (2019). Implications of application programming interfaces for third-party new app development and copycatting. *Production and Operations Management*, 28(8), 1887–1902. <https://doi.org/10.1111/poms.13021>.
- Yi, J., Lee, Y., & Kim, S.-H. (2019). Determinants of growth and decline in mobile game diffusion. *Journal of Business Research*, 99, 363–372. <https://doi.org/10.1016/j.jbusres.2017.09.045>.
- Yoo, Y., Henfridsson, O., & Lyytinen, K. (2010). Research commentary—The new organizing logic of digital innovation: An agenda for information systems research. *Information Systems Research*, 21(4), 724–735. <https://doi.org/10.1287/isre.1100.0322>.
- Zhao, Y., von Delft, S., Morgan-Thomas, A., & Buck, T. (2019). The evolution of platform business models: Exploring competitive battles in the world of platforms. *Long Range Planning*, 101892. <https://doi.org/10.1016/j.lrp.2019.101892>.
- Zhao, Z., & Balagué, C. (2015). Designing branded mobile apps: Fundamentals and recommendations. *Business Horizons*, 58(3), 305–315. <https://doi.org/10.1016/j.bushor.2015.01.004>.
- Zhou, G., & Song, P. (2018). Third-party apps (TPAs) and software platform performance: The moderating role of competitive entry. *Information & Management*. <https://doi.org/10.1016/j.im.2018.04.004>.
- Zhu, F., & Iansiti, M. (2012). Entry into platform-based markets. *Strategic Management Journal*, 33(1), 88–106. <https://doi.org/10.1002/smj.941>.
- Zhu, F., & Iansiti, M. (2019). Why some platforms thrive and others don't. *Harvard Business Review*, 97(1), 118–125. bth.
- Zhu, F., & Liu, Q. (2018). Competing with complementors: An empirical look at Amazon.com. *Strategic Management Journal*, 39(10), 2618–2642. <https://doi.org/10.1002/smj.2932>.

Javier Cenamor (Ph.D.) is a senior lecturer at the Department of Business Administration and an affiliated member of CIRCLE at Lund University, Sweden. His research interests include platform-mediated ecosystems, strategic management, and product-service systems. He has published on these topics in *Technovation*, *Journal of Business Research*, *International Journal of Production Economics*, *Decision Support Systems*, *Industrial Marketing Management*, *Sustainability*, and others.