



# The impact of coronavirus pandemic (COVID-19) on education: The role of virtual and remote laboratories in education

Rabab Ali Abumalloh<sup>a</sup>, Shahla Asadi<sup>b</sup>, Mehrbakhsh Nilashi<sup>c,d,\*</sup>, Behrouz Minaei-Bidgoli<sup>d</sup>, Fatima Khan Nayer<sup>e</sup>, Sarminah Samad<sup>f</sup>, Saidatulakmal Mohd<sup>h,\*\*</sup>, Othman Ibrahim<sup>g</sup>

<sup>a</sup> Computer Department, Community College, Imam Abdulrahman Bin Faisal University, P.O. Box. 1982, Dammam, Saudi Arabia

<sup>b</sup> Centre of Software Technology and Management, Faculty of Information Science and Technology, Universiti Kebangsaan Malaysia, 43600, Bangi, Selangor, Malaysia

<sup>c</sup> Centre for Global Sustainability Studies (CGSS), Universiti Sains Malaysia, 11800, George Town, Malaysia

<sup>d</sup> School of Computer Engineering, Iran University of Science and Technology, Iran

<sup>e</sup> College of Computer and Information Sciences, Prince Sultan University, Saudi Arabia

<sup>f</sup> Department of Business Administration, College of Business and Administration, Princess Nourah bint Abdulrahman University, Riyadh, Saudi Arabia

<sup>g</sup> Azman Hashim International Business School, Universiti Teknologi Malaysia (UTM), Skudai, Johor, 81310, Malaysia

<sup>h</sup> Centre for Global Sustainability Studies & School of Social Sciences, Universiti Sains Malaysia, Malaysia

## ARTICLE INFO

### Keywords:

Push-pull-mooring framework  
COVID-19  
Coronavirus pandemic  
Virtual laboratories  
Education

## ABSTRACT

To avoid the spread of the COVID-19 crisis, many countries worldwide have temporarily shut down their academic organizations. National and international closures affect over 91% of the education community of the world. E-learning is the only effective manner for educational institutions to coordinate the learning process during the global lockdown and quarantine period. Many educational institutions have instructed their students through remote learning technologies to face the effect of local closures and promote the continuity of the education process. This study examines the expected benefits of e-learning during the COVID-19 pandemic by providing a new model to investigate this issue using a survey collected from the students at Imam Abdulrahman Bin Faisal University. Partial Least Squares Structural Equation Modeling (PLS-SEM) was employed on 179 useable responses. This study applied Push-Pull-Mooring theory and examined how push, pull, and mooring variables impact learners to switch to virtual and remote educational laboratories. The Protection Motivation theory was employed to explain how the potential health risk and environmental threat can influence the expected benefits from e-learning services. The findings revealed that the push factor (environmental threat) is significantly related to perceived benefits. The pull factors (e-learning motivation, perceived information sharing, and social distancing) significantly impact learners' benefits. The mooring factor, namely perceived security, significantly impacts learners' benefits.

## 1. Introduction

Given the growing number of reported infected cases at Chinese and international locations, the WHO Emergency Committee announced a worldwide health crisis on January 30, 2020 [1–4]. Young and healthy grownups have comparatively fewer death risks, whereas those above the 60s, and especially 80s, are at disproportionately higher risks of death [5,6]. Particular care and efforts should be taken to save extremely susceptible people such as kids, medical staff, and older people [7,8]. People with high blood pressure, heart disease, diabetes,

cancer, and chronic respiratory disease have larger death rates [9]. The increased death rate among those groups is important to consider by supporting social distance interventions, which are ideal for protecting all population groups [10,11].

With COVID-19 spreading throughout the world, governments have imposed unprecedented quarantines and travel bans [12–14]. In the last week of March 2020, educational systems faced an important milestone in the national academic plan towards distance education. According to UNESCO, approximately more than 11 billion school students were affected by the pandemic closures, in which 191 countries had

\* Corresponding author.

\*\* Corresponding author.

E-mail addresses: [rababemad2@yahoo.com](mailto:rababemad2@yahoo.com) (R.A. Abumalloh), [nilashidotnet@hotmail.com](mailto:nilashidotnet@hotmail.com) (M. Nilashi), [b\\_minaei@iust.ac.ir](mailto:b_minaei@iust.ac.ir) (B. Minaei-Bidgoli), [eieydd@usm.my](mailto:eieydd@usm.my) (S. Mohd).

<https://doi.org/10.1016/j.techsoc.2021.101728>

Received 23 September 2020; Received in revised form 1 July 2021; Accepted 1 September 2021

Available online 13 September 2021

0160-791X/© 2021 Elsevier Ltd. All rights reserved.

nationwide closures and five had regional locks, affecting about 91.3% of the global public of students [15]. Many remote learning platforms like Google Classroom, Coursera, Udacity, and many more are utilizing e-learning platforms to allow the learning process during the COVID-19 pandemic [16]. For example, Coursera has offered numerous free courses for students to learn at home. Still, electronic education demands conscientious investigation of how students and educators manipulate the shifting. It also requires a critical examination of whether the education manner continues to be efficient when it is based on electronic technological tools.

Societies meet unexpected and emerging obstacles, which have been indicated in previous studies as “grand challenges” [17]. Ferraro et al. [18] indicated that grand challenges could be characterized by their complexity as they support several communications. Grand challenges need to be addressed using scientific development through several technological tools. Previous studies indicated the significant part of scientific collaboration using advanced technologies among students, instructors, scientists, academics, and researchers to address these challenges [19]. Collaborative electronic learning provides timely solutions to obstacles linked to traditional learning. These obstacles should be resolved in the post-COVID-19 time. Collaborative electronic learning supports learners with the ability to conduct distance-based effective meetings, presents additional chances for electronic instructing and coordination, and it promotes knowledge sharing.

The sudden closure of educational institutions in Saudi Arabia, due to the current COVID-19 crisis, led to an unexpected transformation from traditional learning to a plan that particularly entails electronic monitoring and learning. The shutdown of educational institutions put the government under huge pressure with highly restricted choices. The Saudi Ministry of Education declared electronic learning as a replacement for traditional learning to keep students and families safe. This large unintended shift has allowed new methods to be applied in delivering the content of courses for learners. Among these educational institutions, Imam Abdulrahman Bin Faisal University has adopted electronic learning during this crisis, for the second academic term of 2019–2020 and the first term of 2020–2021. Faculty members were encouraged to utilize all available electronic services to continue the learning process in the online mode using the blackboard system supported by the university portal.

In light of the above, the goal of this study can be achieved by investigating the most influential factors that can impact the perceived expected benefits of virtual and remote laboratories during the COVID-19 pandemic. To achieve the goal of the study, two theoretical grounds were utilized, Pull-Push-Mooring (PPM) theory and Protection Motivation Theory (PMT), to present the hypothesized relationships in the proposed model. Accordingly, based on the quantitative approach, data was gathered and analyzed using PLS-SEM. The theoretical contribution of this study can be indicated by integrating these theories in the current emerging context and by presenting the research variables to explore the expected benefits of e-learning during the COVID-19 crisis. Although many previous studies have explored the variables that impact the adoption of e-learning in several contexts [20–26], this unexpected switch from traditional to online education has presented an extraordinary context, which has not been explored in prior studies. People worldwide are questioning whether online education will proceed after the pandemic, and how this switch would influence the global education system. Considering the novelty of the research context, this study aims to tackle these issues by examining the factors influencing electronic education’s success during the pandemic.

## 2. Theoretical background

### 2.1. Pull-push-mooring (PPM) theory

In the study presented by Lee [27]; it was found that people’s migration is shaped by push and pull constructs. Adopting this idea, a

Push-Pull model was developed according to Ravenstein’s migratory laws. Push effects are negative factors, while pull effects are positive factors. Given that push-pull factors did not clarify how human beings can identify their movements on a social and individual basis, the mooring factor was later inserted into the Push-Pull model by Moon [28]. The ‘mooring’ factor presents further variables that influence the switching behavior and simplify it [29]. The mooring constructs inter-communicate with the push and pull constructs, which can help in deciding to move, referring to how easier or more difficult the movement is [30]. Following that, Bansal et al. [31] utilized the PPM framework successfully, as a dominant paradigm in human migration literature, to explore its applicability in consumers’ behavior context. Bansal et al. [31] indicated the resemblance between migration and the shifting action in the service context. They incorporated several variables in the PPM model to explain the consumer’s shifting action in the hairdressing and vehicle mend service context. Afterward, many studies have been using PPM to explore the individual’s switching or shifting behavior as an effective theoretical framework. These studies indicated that although the PPM model originated from the migration theory, it can be used effectively to explain people’s shifting actions [29]. The migration is not only considered as a shift from a specific physical region to another but it can also be expanded to several daily actions. Specifically, switching behavior can be considered as a special class of migration.

Previous studies have used the PPM model as a beneficial useful framework, as it can be inspected empirically, referring to a wide range of electronic service switching scenarios [32]. Hence, articles have investigated the switching activities in the IS field by adopting the PPM, such as blog applications [33], web browsers [34], mobile applications [35], and social platforms [36,37].

Lehto et al. [38] adopted the PPM framework to inspect visitors’ intentions to switch in the context of travel and leisure business. In another context of social networks, Chang et al. [39] utilized the PPM theory to explore users’ intentions to switch. Ye and Potter [34] applied the PPM model to explore the switching activities of users of web browsers and indicated the impact of habit on shifting intentions and switching actions. Additionally, Sun et al. [40] deployed the PPM framework to inspect the switching activities of users of mobile instant messaging. Zhang et al. [33] explored customers’ shifting intentions for weblog service vendors. The result of the study supported the theoretical ground of PPM theory and indicated that among the proposed variables, satisfaction is the most influential variable on shifting intention. On the other hand, Hou et al. [41] adopted the PPM model to the electronic role-playing game service field. Additionally, Hsieh et al. [36] utilized the PPM model to assess the crucial factors that impact the shifting intention from blogs to social media platforms.

Hence, building on previous literature, this study tries to use this theoretical ground by adopting push-pull-mooring factors to explain learners’ perceptions of the expected benefits from online learning during the COVID-19 crisis. In particular, this research aims to meet the research objective through the lens of the PPM framework. The PPM model works as an incorporated framework to explore various factors that impact users’ switching actions, entailing push, pull, and mooring factors.

### 2.2. Protection motivation theory (PMT)

PMT is regarded as one of the most prominent theoretical grounds in the health-related action stimulus [42,43]. In the information system context, anticipating the intention to involve in protective actions has been investigated by many types of research [44–46]. PMT indicates two main directions in motivating the individuals to adopt protective actions: risk evaluation and coping evaluation [44,47]. Risk evaluation is one’s estimation of the degree to which a potential risk is possible to happen and how serious it can be. Hence, in this research, the perceived threat imposed by COVID-19 and the perceived environmental risk can

impact people's protective actions. PMT highlights that the coping assessment action only happens if a potential risk exists, and it occurs after the risk assessment procedure [44]. Coping assessment particularly entails the individual choice regarding if he can efficiently handle the risk or not [44].

Several factors can increase students' motivations in using electronic learning. If the risk linked to a particular action (continuing traditional learning) is regarded as serious, the user's motivation to use other safer choices will be high. Additionally, if the user can perceive the benefits of online learning to minimize the negative impacts associated with a specific situation, this can enhance his motivation to utilize the perceived benefits. Hence, if the user trusts that he can use electronic platforms to learn, his motivation will be high, and his switching action is more likely to happen, referring to PMT theory. Adopting this theory allowed us to hypothesize that two factors will influence the expected benefits from e-learning; environmental threat and perceived health risk. First, suppose if a student believes that restricting education to traditional learning can lead to an increased threat to the environment, this will impact his perception of the benefits of other choices. Environmental pollution can maximize the risk of other health-related serious problems (threat appraisal). The threat appraisal will motivate the learner to change towards other choices (e-learning) and his perception of the expected benefits will improve. This goes in line with a previous study by Langbroek et al. [48]; which indicated that users who perceive air pollution threats more seriously have more willing to shift to green transportation. Second, if the student believes that attending traditional classes and communicating with others (face-to-face) can maximize the threat of the infection of serious health disease (threat appraisal), his motivation to change will increase and his perception of the expected benefits will improve.

### 3. Research model and hypotheses development

In the development protocol of the research model, previous methods for assessing virtual and remote learning and previous IS literature were considered to provide a broad definition of the success of virtual and remote learning. Therefore, various perspectives were considered with the inclusion of pull factors (e-learning motivation, perceived information sharing, and social distancing); push factors (environmental threat and perceived health risk); and mooring factor (perceived security) based on their potentials to appraise the achievement of virtual and remote learning. These dimensions encompass the main components of the offered research model. We target to explore the impact of each factor on learners' expected benefits of utilizing the virtual and remote learning system by developing a comprehensive research model and empirically testing it in light of the research context.

Push factors in this research focus on the negative characteristics of face-to-face learning in the situation of the COVID-19 pandemic, and how these factors may drive individuals away from traditional learning. Traditional learning's negative attributes are found in two main categories: psychological and situational variables [49]. Considering the study objective, environmental threat and perceived health risk are identified as the negative characteristics of traditional learning from psychological and situational aspects. The pollution of the environment and the risk of health are considered negative attributes of traditional learning in this study.

In this research, the relationships between the pull factors (e-learning motivation, perceived information-sharing, and social distancing) and perceived benefits are also investigated. The study assumes that people would rationally assess the advantages of virtual and remote laboratories, which are reflected by information sharing. Students also consider their aims from using the online portals for educational perspectives, which are reflected by their motivations to use the online portal. This study assumes that students will perceive social distancing as a positive feature of online learning that will pull them towards using online portals. In virtual and remote laboratories, rational

and social perceptions emerge simultaneously. Hence, it is vital to examine the variables that can promote the expected benefits from virtual and remote learning with the consideration of e-learning motivation, information sharing, and social distancing. Finally, it is vital to examine the user's perception of the security of the electronic platforms to promote the switching process [50]. The hypothesized model is displayed in Fig. 1. The hypotheses of this research are discussed in the following sections.

#### 3.1. E-learning motivation and perceived benefits

One of the obstacles that confront people in the academic sector is encouraging learners to study [51]. Academic standards show that unconcerned or careless learners, who conduct the least effort in performing academic tasks, have been a center of worry agreed by educators and researchers [52,53]. Unconcerned learners provide less motivation in strengthening their academic levels and present more care about the grades than the learning process. The e-learning motivation variable reflects learners' tendency to perceive e-learning services as useful and simple to use and to get the required academic gains from using the system [54]. Previous studies have explored the impact of learning motivation based on several aspects related to the learning context [50,51,55]. The motivation variable has a vital impact on usage intention [56,57]. Ryan and Deci [58] categorized motivation as intrinsic and extrinsic. Intrinsic motivation indicates the individual action to fulfill his enjoyment and satisfaction [59]. On the other hand, extrinsic motivation is related to broad categories of actions that are committed to get other benefits rather than the individual self-interest [50]. In the context of this research, learners use the virtual system to gain the needed information, which is required to obtain the course grades. Hence, in this research, we focus on extrinsic motivation as a prerequisite to learners' benefits. Hence, following the above discussion, we present the next hypothesis:

**H1.** E-learning motivation has a significant impact on perceived benefits.

#### 3.2. Environmental threat and perceived benefits

Environmental threats represent the degree to which the person thinks that the environmental-related challenges have negative implications [60]. Referring to the protection motivation theory, the individual conducts particular protective behaviors following the assessment of a specific threat related to a specific issue [61]. In the context of this research, protective behavior will be prompted by the individual perception of environmental threats [49]. People are more willing to perform eco-friendly movements when they have negative emotions considering environmental issues. The desire to preserve the environment arises when people gain awareness of potential threats [62]. As indicated by Kim et al. [63]; the potential risks of climate change affect people's readiness to behave favorably towards the environment positively. As people's behavioral patterns have converted because of the COVID-19 pandemic, people's negative influence on the environment has decreased. Pollution degrees are presenting vital reductions regarding the quarantine rules. All these aspects have raised people's awareness of environmental issues. A study by Rousseau and Deschacht [64] has indicated the impact of COVID-19 on improving people's awareness of nature problems. It can be anticipated that the current crisis has raised individuals' perceptions of environmental risks. Thus, it can be hypothesized that when people sense environmental enhancement during and after the COVID-19, they will be more willing to perceive the virtual learning benefits. Accordingly, the next hypothesis can be presented:

**H2.** The environmental threat has a significant impact on perceived benefits.

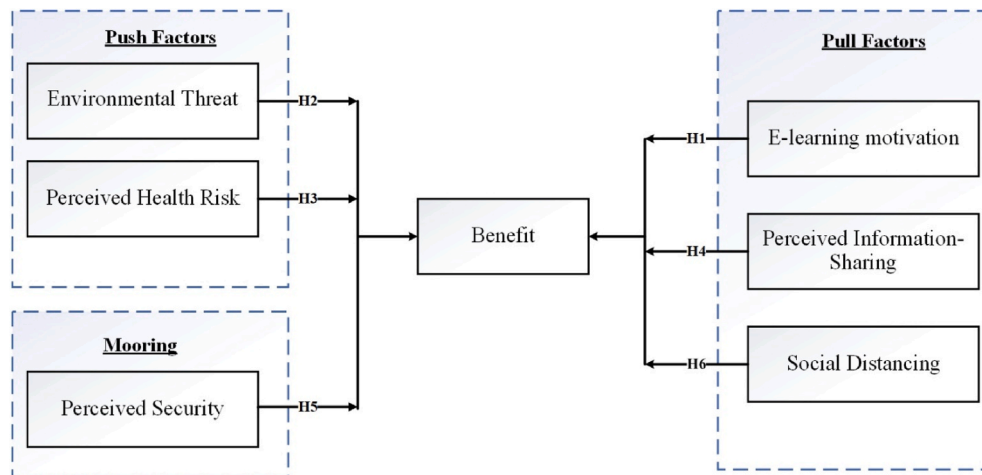

Fig. 1. The research model.

### 3.3. Perceived health risk and perceived benefits

The Health Belief Model (HBM) indicates that people who believe that there is a potential health risk are more willing to participate in healthy actions [65]. People with greater levels of perception of health-related threat have a higher desire to adjust their actions or to shift to health-based actions, such as following protective health actions [66–69]. Several studies have indicated the influence of perceived health risk on people’s health-related behaviors [68,70,71]. The crisis we face has dramatically raised people’s perception of health risks [72–74]. Hence, we suggest that health risks will participate in changing people’s actions significantly. Consequently, following previous literature, we present the following hypothesis:

**H3.** Perceived health risk has a significant impact on perceived benefits.

### 3.4. Perceived information sharing and perceived benefits

This research adopts the perceived information-sharing concept from Dewhirst’s [75] to utilize the pull force that leads learners to exchange their knowledge with their colleagues. In the context of e-learning, sharing the information indicates learners’ awareness of the collaborative e-learning process [76]. Thus, students in the e-learning scenario may develop firm norms of knowledge sharing if they have observed the desire for information exchange in a collaborative manner. The need to acquire the information to continue the learning process during the quarantine period impacts learners’ perceptions of the expected benefits of the e-learning process and allows new modes of information sharing among students. While traditional learning restricts the learning process to direct interaction between the instructor and learners, virtual learning enables sharing of recorded lessons and digital materials. Thus, the next hypothesis is presented as follows:

**H4.** Perceived information sharing has a significant impact on perceived benefits.

### 3.5. Perceived security and perceived benefits

Students are the most considerable part of the electronic learning portal’s community [77]. Learners care about the security of the online system. They concern about their private data, as they need to trust the reliability of the electronic portal. Electronic mediums are considered as channels for private information exchange; hence, it is logical that general trust reduces security concerns. These security concerns entail external threats from cybercriminals, the misuse of the information by organizations, and other potential risks [78]. The electronic medium’s

perceived security is essential to increase learners’ perceptions of the expected benefits, as indicated in previous literature [79–81]. Hence, we present the next hypothesis:

**H5.** Perceived security has a significant impact on perceived benefits.

### 3.6. Social distancing and perceived benefits

Social distancing has been recommended and regulated by countries to face the spread of the COVID-19. Many countries have followed movement restrictions to decrease the number of COVID-19 confirmed cases and the crisis’s spread [82]. It is not yet recognized how much time the pandemic will continue, neither the influence it will leave on the education system. Based on the impact of the new regulations and social distancing rules that should be followed to restrict the distribution of the disease, educational organizations can adopt new plans that incorporate the online mode in their strategies. For several academic scholars and educators, the COVID-19 pandemic is regarded as an extraordinary chance to aid both learners and educational facilities in bridging the traditional learning gaps. Still, to properly shift to virtual learning, essential prerequisites should be achieved: access to the world wide web, the provision of suitable techniques, and the accessibility to suitable training to utilize online learning. The crisis has highlighted some of the advantages of electronic education; it enables both academics and learners to proceed with the learning process without disruption and allows the reach to teaching materials anytime and everywhere [83]. Social distancing can foster the shift to virtual learning and the utilization of its benefits. Hence, according to the above discussion, we present the next hypothesis:

**H6.** Social distancing has a significant impact on perceived benefits.

## 4. Data collection

Determining the research sample is a significant step in quantitative research. Referring to the context of this research, college students were utilized as a research sample in several studies in information technologies’ adoption context in general [84–86], and in the context of electronic learning particularly [87,88]. College students constitute a huge portion of internet users and are represented by the term “Net Generation”. As common worldwide web users, they are usually used for large-scale internet surveys. Further reasons for choosing college students include their understanding of e-services, their familiarity with electronic media, and their usage of e-services for communication [89]. In light of the above, college students are considered to be representative of the study population.

A 5-point Likert scale has been adopted to evaluate the survey

questionnaire, based on the research model and the research hypotheses. The data was collected through an online questionnaire, as we invited respondents through their e-mails in Imam Abdulrahman Bin Faisal University in Saudi Arabia to answer the survey. During the COVID-19 pandemic, the university has shifted the learning process from traditional learning to virtual classes through the blackboard system. The blackboard system has many tools that have been utilized in the e-learning process, such as online assessments, online exams, and blackboard collaboration. The data was gathered from Computing, Business Administration, and English departments. The survey was launched in June 2019, for one month. The period for distributing the data was chosen specifically at the end of the second semester of the academic year 2019/2020, to reflect students' experiences with online education after more than three months of the actual usage. The age of the students ranges from 18 to 23 years old. To avoid the occurrence of missing values and bias results, the elimination of observations was adopted. All subjects were asked to respond to the questionnaire and their responses were confidentiality guaranteed. Constructs and their measurement items are provided in Appendix A. Finally, to determine the least required sample size, G\*power software was used. Referring to Faul et al. [90]; we adopted the following settings of the program ( $f^2 = 0.15$  for effect size,  $\alpha = 0.05$  for error type one, and  $\beta = 0.20$  for error type two) and for six independent factors, the least recommended sample size was 98. Hence, the sample size of this study is adequate.

4.1. Data analysis and results

Through running SmartPLS 3.0, the SEM approach was used to test the measurement model and the study's hypotheses. A partial least square is ideal for evaluating latent variables or high-level models of hierarchical content. Considering the recommendations proposed by Hair Jr et al. [91]; measurement models were tested separately before the structural model assessment. PLS algorithm by bootstrapping (5000 resample) was used to evaluate items' factor loadings, path coefficients of relationships, and their respective significance levels.

4.2. Measurement model testing

Measurement model evaluation is the first step in every SEM process. Three main criteria were used to assess the measurement model: reliability, convergent validity, and discriminant validity following Hair Jr et al. [91] and Asadi et al. [92]. As indicated in Table 1, Cronbach  $\alpha$  is above the recommended 0.70 value, indicating strong reliability of all measures. The composite reliability is between 0.846 and 0.905. This outcome goes beyond the recommended value (0.70) (Hair et al., 2010). AVE was used to test convergent reliability. The AVE value for all constructs is higher than 0.5, which confirms the latent model variables' confidence and validity [91,93]. The discriminant validity of the measurement model was assessed based on the correlation matrix or cross-loadings. The AVE's square root must be higher than the correlation between one construct and others, as determined by Fornell and Larcker [94] (see Table 2). The outcome of the test confirms the desired output of the Fornell and Larcker test.

The assessment of the cross-loading values in reflective indicators is the next evaluation of the model's discriminant validity. We used the cross-loading method to evaluate the constructs' discriminant validity to test our research model [95]. As shown in Appendix B, each measurement indicator's load on its related variable is higher than its load on any other variable in the model. Thus these findings fulfill the cross-load assessment criteria and demonstrate the discriminant validity of the model adequately.

4.3. Structural model results

Fig. 2 demonstrates the  $\beta$  values and path coefficients for the relationships between the proposed model's constructs. The bootstrapping

Table 1  
Constructs' reliability and convergent validity.

Constructs	Indicator	Outer loading	Composite Reliability (CR)	Cronbach's Alpha (CA)	AVE
Benefits	BN1	0.824	0.905	0.868	0.657
	BN2	0.854			
	BN3	0.855			
	BN4	0.8			
	BN5	0.712			
E-learning motivation	ELM1	0.713	0.846	0.763	0.58
	ELM2	0.79			
	ELM3	0.781			
	ELM4	0.761			
Environmental Threat	ET1	0.88	0.869	0.771	0.689
	ET2	0.87			
	ET3	0.732			
Perceived Health Risk	PHR1	0.821	0.884	0.825	0.655
	PHR2	0.839			
	PHR3	0.772			
	PHR4	0.804			
Perceived Information-Sharing	PIS1	0.759	0.861	0.784	0.608
	PIS2	0.748			
	PIS3	0.837			
	PIS4	0.771			
Perceived Security	PS1	0.815	0.894	0.851	0.628
	PS2	0.848			
	PS3	0.827			
	PS4	0.754			
	PS5	0.712			
Social Distancing	SD1	0.845	0.86	0.755	0.672
	SD2	0.866			
	SD3	0.743			

Table 2  
Fornell-larcker criterion analysis.

	BN	ELM	ET	PHR	PIS	PS	SD
BN	<b>0.811</b>						
ELM	0.758	<b>0.762</b>					
ET	0.732	0.653	<b>0.83</b>				
PHR	0.629	0.635	0.572	<b>0.809</b>			
PIS	0.741	0.692	0.628	0.564	<b>0.78</b>		
PS	0.791	0.702	0.68	0.679	0.686	<b>0.793</b>	
SD	0.793	0.662	0.69	0.697	0.659	0.762	<b>0.82</b>

Note: BN: Benefits; ELM: E-learning motivation; ET: Environmental Threat; PHR: Perceived Health Risk; PIS: Perceived Information-Sharing; PS: Perceived Security; SD: Social Distancing.

algorithm evaluates the path coefficient's importance in PLS by considering 5000 bootstrap samples in PLS-SEM. The p-values and t-values are employed to assess whether  $\beta$  value is statistically significant at a 5% error probability. To accept research hypotheses, a statistical significance level of 5% indicates that the p-value must be less than 0.05 and a t-value should be greater than 1.96. Table 3 and Fig. 2 provide a summary of the results of the examination of the hypotheses. The final model of this research is, therefore, provided in Fig. 3.

5. Discussion

The main goal of this research is to examine the relationship between push, pull, and mooring factors and virtual and remote classes' expected benefits in the case of the COVID-19 crisis. According to the proposed hypotheses, the push factor, environmental threat ( $t = 2.677$ ;  $p = 0.007$ ;  $\beta = 0.156$ ); is significantly related to perceived benefits, whereas the pull factors, including e-learning motivation ( $t = 3.302$ ;  $p = 0.001$ ;  $\beta = 0.216$ ), perceived information sharing ( $t = 2.437$ ;  $p = 0.015$ ;  $\beta = 0.177$ ), and social distancing ( $t = 3.775$ ,  $p = 0$ ;  $\beta = 0.291$ ) have significant impacts on learners' benefits. Moreover, the mooring factor, namely perceived security ( $t = 3.04$ ;  $p = 0.002$ ;  $\beta = 0.228$ ), significantly impacts

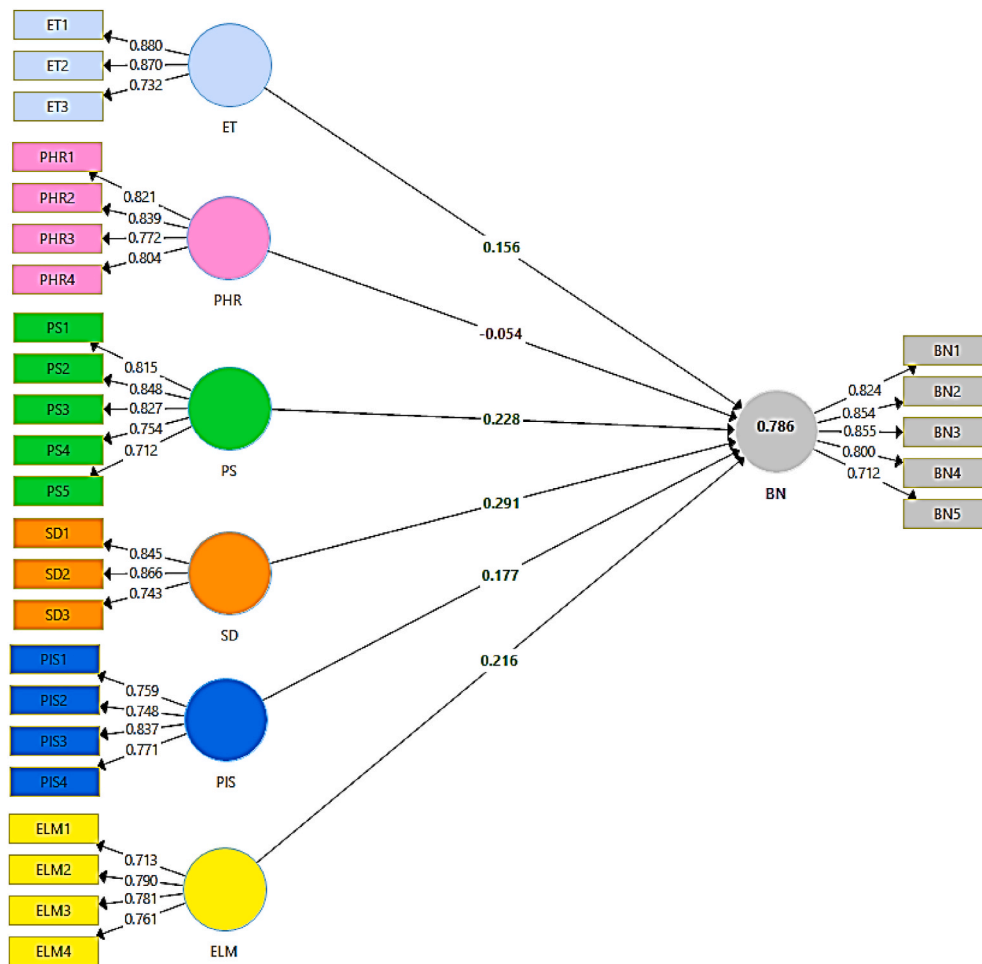

Fig. 2. Structural model path coefficients.

Table 3  
Results of hypotheses testing.

	Hypotheses	Original Sample	Sample Mean	Standard Deviation (STDEV)	T Statistics ( O/STDEV )	P Values	Result
H1	ELM - > BN	0.216	0.211	0.065	3.302	0.001**	Supported
H2	ET - > BN	0.156	0.156	0.058	2.677	0.007**	Supported
H3	PHR - > BN	-0.054	-0.052	0.071	0.753	0.452	Not Supported
H4	PIS - > BN	0.177	0.185	0.072	2.437	0.015*	Supported
H5	PS - > BN	0.228	0.23	0.075	3.04	0.002**	Supported
H6	SD - > BN	0.291	0.284	0.077	3.775	0**	Supported

Note: Significance level = \* <0.05, \*\* <0.01.

learners' benefits.

As H2 gained empirical support, student's perceived benefits are affected by perceived environmental threats. This result goes consistently with the result provided by Wang et al. [49]; in which the perceived environmental threats significantly influence the individual's willingness to shift. This study also confirmed the outcomes of a study by Fu [96] which indicated that the push factor "threat appraisal" has a significant influence on career commitment. On the other hand, the impact of perceived health risk on the expected benefits was not supported in this study. This outcome contradicts a study by Ahadzadeh et al. [70]; which demonstrated the impact of the perceived health risk on internet use. Still, the context of the study is relatively new, and different outcomes are expected.

The findings of this research demonstrated that the pull effect is a major power to switch to online learning and gain the expected benefits. The pull effect of this research is based on the user's perception of the e-learning platform and the perception of social distancing measures. As

indicated by previous studies, e-learning motivations can play a major role in the technological acceptance context [32,54], which was highlighted by our results. Also, information sharing is found to be important to improve the perceived gains. The identified effect from the pull factors demonstrated that the need for information sharing impacts the expected benefits of virtual classes. Allowing cooperative actors to address the ambiguity they face can ensure that the process of coordination is understood and conflicts between communicative actions are reduced. The result of the study presented by Shih [76] is consistent with this result. Two examples from the previous studies indicated the importance of active interaction between involved parties in cooperative-based functions. First, Zack [97] indicated the importance of using effective technological tools within a shared scenario. Second, a study by Kraut and Streeter [98]; which emphasized the role of information sharing and collaborative actions on teamwork performance.

The results have also confirmed the influence of social distance on e-learning benefits. Social distancing plays an important part in the

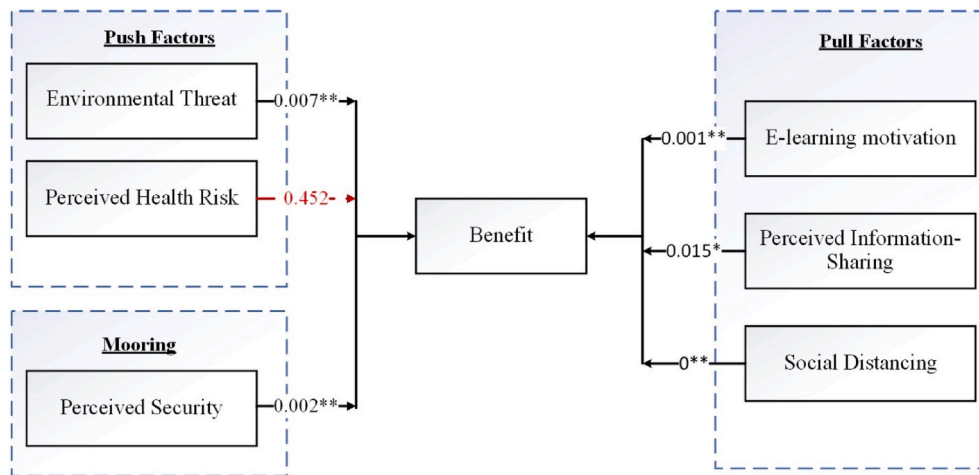

Fig. 3. Result of hypotheses testing.

study's context, which has not been examined before. Virtual classes are vital tools for educators and students and valuable mechanisms for spreading the awareness of the public health issues for universities and educational organizations during the national and global restriction rules. Online learning enables the redirection of school and university educational services to homes, as well as routine learning services, in a way that reflects social distancing. Social distancing is a new factor in this emerging condition and it is anticipated that it imposes a vital influence on the user's perception of the e-learning benefits, as supported by research outcomes. This result is consistent with the finding presented by Liu et al. [99]; which emphasizes the significant impact of social distancing on online behavior.

Finally, perceived security has an important impact on perceived benefits. The security of an e-learning system is very important in order not to hinder the information sharing process in the system. Most e-learning systems offer the services needed to communicate regardless of time and space, including forums, e-mails, online evaluations, learning resources, and notices [77]. Since it is a web-based system, computer security threats are encountered. The research has shown that the expected benefits of e-learning systems are linked to the system's security level. This outcome supports the results of previous literature [79–81], which indicated that perceived security is important to increase learners' perceptions of the expected benefits.

## 6. Theoretical implications

This research examines the expected benefits focusing on individuals' shifting behaviors to virtual learning through the lens of the push-pull-mooring framework and PMT theory and highlights the importance of the push, pull, and mooring factors. The results of the research can provide several insights. As expected, learners' benefits are positively affected by one push factor (perceived environmental threat), three pull factors (e-learning motivation, perceived information sharing, and social distancing), and one mooring factor (perceived security). However, perceived health risk didn't impact learners' benefits positively.

Firstly, this research presents the PPM model to frame a comprehensive thought of the potential factors that can influence user's perceived benefits by shifting from traditional learning to online learning in the context of COVID-19. Besides, this research extends the deployment of the PPM model in the context of electronic services. Additionally, by adopting the PMT, the results indicated a significant link between the environmental threat and expected benefits, which presents additional support to the applicability of the PMT in new contexts. The outcome of the research supports the result by Langbroek et al. [48]; which adopted the PMT to explore users' adoption of electric

cars as eco-friendly action.

This study's second contribution is to develop an important model for assessing the success of e-learning in light of the coronavirus pandemic. This model was designed to evaluate e-learning success based on an intensive review of the literature. The new model is considered comprehensive because various factors of environmental threats, perceived health risks, perceived security, the motivation of e-learning, information sharing, and social distancing, were incorporated. Additionally, the model is based on two basic theoretical aspects (PPM and PMT), to explore the perceived benefits of e-learning systems. The present research displays how these elements impact learners' perceptions, thereby extending prior studies in the context of shifting activities.

Third, this study offered an empirical exploration of the developed model that incorporates factors that affect the success of online learning systems. All factors (except health risk), which were hypothesized in the model, were important measures that can help to identify e-learning success factors and their expected benefits in light of the COVID-19 pandemic. The current research examined the relationship between environmental threats and benefits, perceived health risks and benefits, social distancing and benefits, information sharing and benefits, e-learning motivation and benefits, and finally, security and benefits. These hypotheses were not incorporated and examined previously empirically in prior studies. The impacts of these variables were considered focusing on the acceptance of the system in previous studies in other contexts. To the best of our knowledge, this is the first study in which the success of e-learning has been thoroughly identified and empirically examined in one single model focusing on the COVID-19 pandemic. A summary of the theoretical implications of this study is presented in Fig. 4.

## 7. Practical implications

The rapid spread of COVID-19 caused all educational institutions to shut down. Therefore, students who stay home need to be approached with solutions to continue their learning [100]. To maintain the educational process, many proposals have promoted online learning during the lockdown time. In some cases, the online session was streamed live by the instructor to reach learners using video conferencing. In other cases, lectures were recorded and sent to students through particular platforms. All these online education innovations have significantly assisted in directing students to follow lockdown rules. This experience can educate decision-makers to step up towards the use of virtual platforms and tools in the future. The study findings emphasize that continuous improvement of e-learning systems is necessary to be addressed to solve the learning issues and shortfalls during the COVID-19 pandemic. Almost all learning can be conducted in

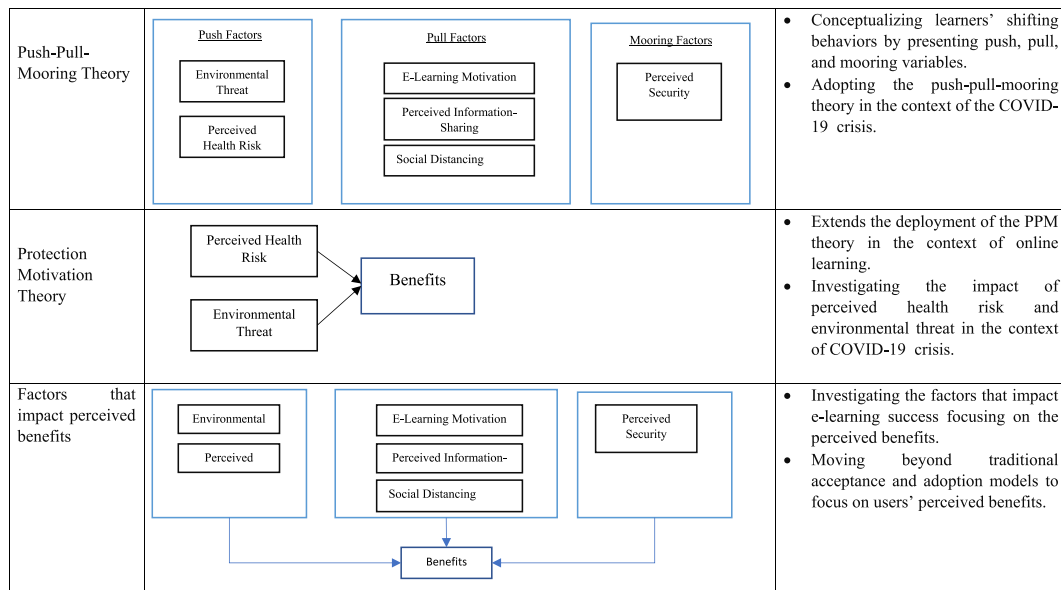

Fig. 4. Theoretical implications.

the form of e-learning except practical teaching which involves mechanical manipulation, machinery, and chemical and biological specimens. Although clinical examination and treatment can be challenging to do via e-learning, clinical education can be manipulated to some degree through e-learning. Hence, during the COVID-19 pandemic, remote learning technologies can be effective if appropriate strategies and initiatives are followed. Hence, decision-makers in the education field need to encourage instructors and students to effectively use these technologies in the quarantine period.

Hence, several practical implications can be concluded by the current study. First, how to attract individuals to use electronic platforms is of great significance for decision-makers. The pull influence, which is triggered by users' positive reactions to the motivation of electronic learning is important to increase the perceived benefits. Therefore, decision-makers should treat increased motivation as a basic planning aim, to empower students' awareness of the benefits of the electronic platform. Effective communication between students and instructors promotes their engagement in the educational process and their social interaction. Hence, efforts should enhance the level of interaction among involved parties, which can enhance the information sharing among users. This can be enabled by indicating, recognizing, and rewarding users who interact most through the electronic platforms. Information sharing enables concerned parties to handle the uncertainty and assure effective cooperation and coordination processes, allowing minimizing challenges among communicative parties in the learning process. Active interaction linked with information-sharing allows all parties to meet desired goals and minimize cognitive gaps through e-learning platforms. Additionally, regarding the mooring influence, electronic interactions entail a security risk. Therefore, efforts should concentrate on enhancing the security of online systems.

The COVID-19 pandemic has also shown that although it's feasible to present the wide majority of education online, the fast and full switch to online learning has imposed vital stress on the parents of students. Families with parents who have full-time jobs have been struggled to manipulate their timings. Many have suffered and don't see a lengthy swift to online education as an attractive outlook. Decision-makers should address this issue in the future. Furthermore, online education has raised important questions about social skills, developing relationships, and interacting with others. The growth in technology can help partially to overcome these limitations. There is a need to address these aspects in the design of online learning platforms.

### 8. Limitations and future work

In this study, the proposed model can provide several foundations for future research. This research is based on the students' perspectives about e-learning benefits during the COVID-19 pandemic. Accordingly, this study may be further utilized focusing on other groups within the educational systems. Besides, various online learning stakeholder groups (e.g. instructors and managers) could add further perspectives to the research and better understanding of the potential problems that might contradict the success of e-learning systems. The differences between the results can be explained, justified, and compared. Besides, longitudinal research into how the quality of e-learning portals can impact the students' behaviors can reveal further interesting results with continuously evolving technologies. While the current research proved the impact of research variables, except the perceived health risk, on the perceived benefits, more investigation will be needed to explore other variables impacting the e-learning success.

Although distributing the questionnaire in one university can impact the generalizability of the survey outcomes, we believe that the study outcomes can be applied to public college students in Saudi Arabia, as they use comparable electronic platforms and they have to follow the same rules presented by the Ministry of Education in Saudi Arabia. This indicates that other educational institutions (schools, private educational institutions) should be careful in utilizing these outcomes, referring to possible variations that may influence the impact of these variables. Adopting the research outcomes to other countries may require further investigation regarding the tools used in online education, the mode of the study (fully online or partially online), and the period in which students used the online services.

In this study, we included three departments: Computing, Business Administration, and English language departments. Each has courses that can be thought by traditional lecturing and other teaching strategies such as speaking in the English Department, programming languages in the Computing Department, and practical training in the Business Administration Department. All the courses have been shifted to the online mode. Other studies can explore the differences between the nature of the course, the teaching strategy, and the expected benefits.

### Credit author statement

Rabab Ali Abumalloh: Supervision, Conceptualization,



Methodology, Investigation, Software, Data curation, Formal analysis, Writing – original draft, Writing – review & editing, Validation. Shahlha Asadi: Conceptualization, Methodology, Investigation, Software, Data curation, Formal analysis, Writing – original draft, Writing – review & editing, Validation. Mehrbakhsh Nilashi: Supervision, Conceptualization, Methodology, Investigation, Software, Data curation, Formal analysis, Writing – original draft, Writing – review & editing, Validation.

Behrouz Minaei-Bidgoli: Investigation, Writing – review & editing, Visualization. Fatima Khan Nayer: Investigation, Writing – review & editing, Visualization. Sarminah Samad: Conceptualization, Investigation, Writing – review & editing, Visualization. Saidatulakmal Mohd: Investigation, Writing – review & editing, Visualization. Othman Ibrahim: Investigation, Writing – review & editing, Visualization.

**Appendix A. Constructs and their Measurement Items**

Construct	Item	References
Environmental Threat	EA1	Human beings create traffic jams, carbon emissions, and noise.
	EA2	Human beings rise the problem of climate change
	EA3	The emissions of the transportation system pollute the air.
Perceived Health Risk	PHR1	There is a big opportunity that I will be infected by the coronavirus (COVID-19)
	PHR2	One of my family members was infected by the coronavirus (COVID-19).
	PHR3	I am worried about getting infected by the coronavirus (COVID-19).
	PHR4	I have a higher risk of getting infected by the coronavirus (COVID-19).
E-learning motivation	ELM1	I participate in virtual and remote laboratories because learning is significant to me.
	ELM2	I participate in virtual and remote laboratories because I think that e-learning will help me to enhance my academic competence.
	ELM3	I participate in virtual and remote laboratories because I understand that I have to refresh my information to enhance my academic practice.
	ELM4	I engage in the conversation in the virtual and remote laboratory forum because I know that I am being evaluated
Perceived Information-Sharing	PIS1	I need to use the e-learning system to share information with my classmates.
	PIS2	I need to use the e-learning system to transfer documents to my classmates.
	PIS3	I need to communicate with my classmates through virtual and remote laboratories in coordinating my study.
	PIS4	I need to use virtual and remote laboratories to share information with my instructors.
Social Distancing	SD1	I encourage rescheduling, delaying, or avoiding public meetings to support social distance.
	SD2	I support the remote conferences, as a replacement to a face-to-face gathering.
	SD3	I avoid events with large numbers of people or crowds.
Perceived Security	PS1	Using virtual and remote laboratories is secure
	PS2	Security aspect influences using e-learning systems.
	PS3	E-learning provides safe interaction to protect all communications among the participants.
	PS4	Virtual and remote laboratories provide the latest encryption technology to prevent unauthorized intrusion.
	PS5	Virtual and remote laboratories provide firewall protection to restrict illegal interference.
Benefits	BN1	Using virtual and remote laboratories has increased my knowledge.
	BN2	Virtual and remote laboratories are very efficient academic strategies and have aided me to enhance my education procedure.
	BN3	Virtual and remote laboratories make the interaction simpler between the educator and learners.
	BN4	Virtual and remote laboratories save my time in finding resources and reduce costs.
	BN5	Virtual and remote laboratories have aided me to reach my educational aims.

**Appendix B. Loading and Cross-Loading Tests**

**Appendix B: Loading and Cross-Loading Tests**

	BN	ELM	ET	PHR	PIS	PS	SD
BN1	0.824	0.576	0.609	0.446	0.623	0.625	0.663
BN2	0.854	0.641	0.608	0.506	0.688	0.647	0.7
BN3	0.855	0.706	0.598	0.534	0.596	0.644	0.673
BN4	0.8	0.603	0.64	0.522	0.573	0.666	0.628
BN5	0.712	0.537	0.508	0.553	0.514	0.63	0.54
ELM1	0.426	0.713	0.461	0.481	0.545	0.525	0.455
ELM2	0.575	0.79	0.472	0.473	0.499	0.543	0.5
ELM3	0.708	0.781	0.581	0.457	0.555	0.561	0.549
ELM4	0.538	0.761	0.455	0.541	0.518	0.511	0.498
ET1	0.591	0.535	0.88	0.425	0.47	0.565	0.568
ET2	0.663	0.553	0.87	0.513	0.5	0.575	0.616
ET3	0.562	0.538	0.732	0.484	0.6	0.553	0.529
PHR1	0.487	0.528	0.533	0.821	0.481	0.541	0.55
PHR2	0.541	0.568	0.424	0.839	0.468	0.583	0.559
PHR3	0.422	0.407	0.368	0.772	0.37	0.481	0.492
PHR4	0.566	0.532	0.515	0.804	0.49	0.58	0.639
PIS1	0.624	0.602	0.546	0.489	0.759	0.63	0.615
PIS2	0.559	0.462	0.49	0.327	0.748	0.469	0.491
PIS3	0.55	0.542	0.454	0.458	0.837	0.531	0.511
PIS4	0.568	0.542	0.457	0.474	0.771	0.496	0.423
PS1	0.672	0.6	0.556	0.542	0.634	0.815	0.692
PS2	0.653	0.586	0.559	0.588	0.615	0.848	0.687
PS3	0.69	0.56	0.563	0.571	0.572	0.827	0.616
PS4	0.493	0.481	0.5	0.53	0.398	0.754	0.521
PS5	0.597	0.544	0.512	0.458	0.462	0.712	0.477
SD1	0.601	0.54	0.552	0.581	0.506	0.63	0.845
SD2	0.75	0.589	0.63	0.578	0.605	0.669	0.866
SD3	0.58	0.491	0.504	0.56	0.498	0.569	0.743

## References

- [1] B.G. Druss, Addressing the COVID-19 pandemic in populations with serious mental illness, *JAMA psychiatry* (2020).
- [2] A. Fiorillo, P. Gorwood, The consequences of the COVID-19 pandemic on mental health and implications for clinical practice, *Eur. Psychiatr.* (2020) 1–4.
- [3] M. Liebrecht, D. Bhugra, A. Buaeze, R. Schleifer, Caring for persons in detention suffering with mental illness during the Covid-19 outbreak, *Forensic Sci. Int.: Mind and Law* 1 (2020) 100013, <https://doi.org/10.1016/j.fsml.2020.100013>.
- [4] F. Ornell, J.B. Schuch, A.O. Sordi, F.H.P. Kessler, “Pandemic fear” and COVID-19: mental health burden and strategies, *Brazilian Journal of Psychiatry(AHEAD)* (2020).
- [5] J.-n. Jun, J.-h. Lee, COVID-19 mental health support: current status and implications, *Research in Brief* (2020) (4) (2020) 1–3.
- [6] K. Shah, D. Kamrai, H. Mekala, B. Mann, K. Desai, R.S. Patel, Focus on mental health during the coronavirus (COVID-19) pandemic: applying learnings from the past outbreaks, *Cureus* 12 (2020), e7405.
- [7] R. Girdhar, V. Srivastava, S. Sethi, Managing mental health issues among elderly during COVID-19 pandemic, *Journal of Geriatric Care and Research* 7 (1) (2020).
- [8] S. Saadat, D. Rawtani, C.M. Hussain, E. Nvironmental Perspective of COVID-19, *Science of The Total Environment*, 2020, p. 138870.
- [9] D. Browne, D. Roy, D. Phillips, D. Stephenson, D. Shamon, Supporting Patient and Clinician Mental Health during COVID-19 via Trauma-Informed Interdisciplinary Systems, 2020.
- [10] R. Stein, COVID-19 and rationally layered social distancing, *Int. J. Clin. Pract.* (2020), e13501.
- [11] G. Thomson, COVID-19: social distancing, ACE 2 receptors, protease inhibitors and beyond? *Int. J. Clin. Pract.* (2020), e13503.
- [12] Q. Chen, M. Liang, Y. Li, J. Guo, D. Fei, L. Wang, L. He, C. Sheng, Y. Cai, X. Li, J. Wang, Z. Zhang, Mental health care for medical staff in China during the COVID-19 outbreak, *The Lancet Psychiatry* 7 (4) (2020) e15–e16, [https://doi.org/10.1016/s2215-0366\(20\)30078-x](https://doi.org/10.1016/s2215-0366(20)30078-x).
- [13] K.K. Dhir, COVID- 19 Impact on the Jobs of Future, *Business World*, Athena Information Solutions Pvt. Ltd., New Delhi, 2020.
- [14] W.E. Parmet, M.S. Sinha, Covid-19—the law and limits of quarantine, *N. Engl. J. Med.* 382 (15) (2020) e28.
- [15] UNESCO, 290 Million Students Out of School Due to COVID-19: UNESCO Releases First Global Numbers and Mobilizes Response, UNESCO, 2020. Retrieved April 17, 2020, <https://en.unesco.org/news/290-million-students-out-of-school-due-to-covid-19-unesco-releases-first-global-numbers-and-mobilizes>.
- [16] R.M. Elavarasan, R. Pugazhendhi, Restructured Society and Environment: A Review on Potential Technological Strategies to Control the COVID-19 Pandemic, *Science of The Total Environment*, 2020, 138858.
- [17] G. George, J. Howard-Grenville, A. Joshi, L. Tihanyi, Understanding and tackling societal grand challenges through management research, *Acad. Manag. J.* 59 (6) (2016) 1880–1895.
- [18] F. Ferraro, D. Etzion, J. Gehman, Tackling grand challenges pragmatically: robust action revisited, *Organ. Stud.* 36 (3) (2015) 363–390.
- [19] R. Sooryamoorthy, Internet technology and the epistemic strategies of scientists in post-apartheid South Africa: race as a decisive factor, *Technol. Soc.* 40 (2015) 73–81.
- [20] B. Acharya, J. Lee, Users’ perspective on the adoption of e-learning in developing countries: the case of Nepal with a conjoint-based discrete choice approach, *Telematics Inf.* 35 (6) (2018) 1733–1743.
- [21] T.-H. Chu, Y.-Y. Chen, With good we become good: understanding e-learning adoption by theory of planned behavior and group influences, *Comput. Educ.* 92 (2016) 37–52.
- [22] Y. Duan, Q. He, W. Feng, D. Li, Z. Fu, A study on e-learning take-up intention from an innovation adoption perspective: a case in China, *Comput. Educ.* 55 (1) (2010) 237–246.
- [23] H.-L. Liao, H.-P. Lu, The role of experience and innovation characteristics in the adoption and continued use of e-learning websites, *Comput. Educ.* 51 (4) (2008) 1405–1416.
- [24] A. Mehta, N.P. Morris, B. Swinnerton, M. Homer, The influence of values on E-learning adoption, *Comput. Educ.* 141 (2019) 103617.
- [25] S. Yu, I.-J. Chen, K.-F. Yang, T.-F. Wang, L.-L. Yen, A feasibility study on the adoption of e-learning for public health nurse continuing education in Taiwan, *Nurse Educ. Today* 27 (7) (2007) 755–761.
- [26] L. Zhang, H. Wen, D. Li, Z. Fu, S. Cui, E-learning adoption intention and its key influence factors based on innovation adoption theory, *Math. Comput. Model.* 51 (11–12) (2010) 1428–1432.
- [27] E.S. Lee, A theory of migration, *Demography* 3 (1) (1966) 47–57.
- [28] B. Moon, Paradigms in migration research: exploring ‘moorings’ as a schema, *Prog. Hum. Geogr.* 19 (4) (1995) 504–524.
- [29] J. Jung, H. Han, M. Oh, Travelers’ switching behavior in the airline industry from the perspective of the push-pull-mooring framework, *Tourism Manag.* 59 (2017) 139–153, <https://doi.org/10.1016/j.tourman.2016.07.018>.
- [30] O.C. Ojiaku, A.D. Nkamnebe, I.C. Nwazugbo, Determinants of entrepreneurial intentions among young graduates: perspectives of push-pull-mooring model, *Journal of Global Entrepreneurship Research* 8 (1) (2018), <https://doi.org/10.1186/s40497-018-0109-3>.
- [31] H.S. Bansal, S.F. Taylor, St. Y. James, “Migrating” to new service providers: toward a unifying framework of consumers’ switching behaviors, *J. Acad. Market. Sci.* 33 (1) (2005) 96–115.
- [32] Y.-H. Chen, C.-J. Keng, Utilizing the Push-Pull-Mooring-Habit framework to explore users’ intention to switch from offline to online real-person English learning platform, *Internet Res.* 29 (1) (2019) 167–193, <https://doi.org/10.1108/IntR-09-2017-0343>.
- [33] K.Z. Zhang, C.M. Cheung, M.K. Lee, H. Chen, Understanding the blog service switching in Hong Kong: an empirical investigation, in: *Proceedings of the 41st Annual Hawaii International Conference on System Sciences (HICSS 2008)*, IEEE, 2008, 269–269.
- [34] C. Ye, R. Potter, The role of habit in post-adoption switching of personal information technologies: an empirical investigation, *Commun. Assoc. Inf. Syst.* 28 (1) (2011) 35.
- [35] C. Calvo-Porral, J.-P. Lévy-Mangin, Switching behavior and customer satisfaction in mobile services: analyzing virtual and traditional operators, *Comput. Hum. Behav.* 49 (2015) 532–540.
- [36] J.-K. Hsieh, Y.-C. Hsieh, H.-C. Chiu, Y.-C. Feng, Post-adoption switching behavior for online service substitutes: a perspective of the push-pull-mooring framework, *Comput. Hum. Behav.* 28 (5) (2012) 1912–1920.
- [37] C. Zengyan, Y. Yinping, J. Lim, Cyber migration: an empirical investigation on factors that affect users’ switch intentions in social networking sites, in: *2009 42nd Hawaii International Conference on System Sciences*, IEEE, 2009, pp. 1–11.
- [38] X.Y. Lehto, O.-J. Park, S.E. Gordon, Migrating to new hotels: a comparison of antecedents of business and leisure travelers’ hotel switching intentions, *J. Qual. Assur. Hospit. Tourism* 16 (3) (2015) 235–258.
- [39] I.C. Chang, C.C. Liu, K. Chen, The push, pull and mooring effects in virtual migration for social networking sites, *Inf. Syst. J.* 24 (4) (2014) 323–346.
- [40] Y. Sun, D. Liu, S. Chen, X. Wu, X.-L. Shen, X. Zhang, Understanding users’ switching behavior of mobile instant messaging applications: an empirical study from the perspective of push-pull-mooring framework, *Comput. Hum. Behav.* 75 (2017) 727–738.
- [41] A.C. Hou, C.-C. Chern, H.G. Chen, Y.C. Chen, ‘Migrating to a new virtual world’: exploring MMORPG switching through human migration theory, *Comput. Hum. Behav.* 27 (5) (2011) 1892–1903.
- [42] P. Menard, M. Warkentin, P.B. Lowry, The impact of collectivism and psychological ownership on protection motivation: a cross-cultural examination, *Comput. Secur.* 75 (2018) 147–166.
- [43] C. Posey, T.L. Roberts, P.B. Lowry, The impact of organizational commitment on insiders’ motivation to protect organizational information assets, *J. Manag. Inf. Syst.* 32 (4) (2015) 179–214.
- [44] S. Boss, D. Galletta, P.B. Lowry, G.D. Moody, P. Polak, What do systems users have to fear? Using fear appeals to engender threats and fear that motivate protective security behaviors, *MIS Q.* 39 (4) (2015) 837–864.
- [45] A. Burns, C. Posey, T.L. Roberts, P.B. Lowry, Examining the relationship of organizational insiders’ psychological capital with information security threat and coping appraisals, *Comput. Hum. Behav.* 68 (2017) 190–209.
- [46] P. Ifinedo, Understanding information systems security policy compliance: an integration of the theory of planned behavior and the protection motivation theory, *Comput. Secur.* 31 (1) (2012) 83–95.
- [47] I. Topa, M. Karyda, Identifying factors that influence employees’ security behavior for enhancing ISP compliance, in: *International Conference on Trust and Privacy in Digital Business*, Springer, 2015, pp. 169–179.
- [48] J.H.M. Langbroek, M. Cebecauer, J. Malmsten, J.P. Franklin, Y.O. Susilo, P. Georén, Electric vehicle rental and electric vehicle adoption, *Res. Transport. Econ.* 73 (August 2018) (2019) 72–82, <https://doi.org/10.1016/j.retrec.2019.02.002>.
- [49] S. Wang, J. Wang, F. Yang, From willingness to action: do push-pull-mooring factors matter for shifting to green transportation? *Transport. Res. Transport Environ.* 79 (2020) 102242, <https://doi.org/10.1016/j.trd.2020.102242>.
- [50] A.T. Noor, N. Hubbard, Self-determination theory: opportunities and challenges for blended e-learning in motivating Egyptian learners, *Procedia-Social and Behavioral Sciences* 182 (2015) 513–521.
- [51] A.C. Beluche, K.L.d. Oliveira, Students’ motivation for learning in virtual learning environments, *Paideia* 25 (60) (2015) 105–113.
- [52] J.A. Bzuneck, Como motivar os alunos: sugestões práticas, *Motivação para aprender: Aplicações no contexto educativo* (2010) 13–42.
- [53] S.É.R. Guimarães, J.A. Bzuneck, S.F. Sanches, Psicologia educacional nos cursos de licenciatura: a motivação dos estudantes, *Psicologia Escolar e Educacional* 6 (1) (2002) 11–19.
- [54] U.P.T. Maldonado, G.F. Khan, J. Moon, J.J. Rho, E-learning motivation and educational portal acceptance in developing countries, *Online Inf. Rev.* (2011).
- [55] S. Hubackova, Motivation in eLearning Motivation in language courses, *Procedia-Social and Behavioral Sciences* 122 (2014) 353–356.
- [56] F.D. Davis, R.P. Bagozzi, P.R. Warshaw, Extrinsic and intrinsic motivation to use computers in the workplace 1, *J. Appl. Soc. Psychol.* 22 (14) (1992) 1111–1132.
- [57] J.-W. Moon, Y.-G. Kim, Extending the TAM for a world-wide-web context, *Inf. Manag.* 38 (4) (2001) 217–230.
- [58] R.M. Ryan, E.L. Deci, Intrinsic and extrinsic motivations: classic definitions and new directions, *Contemp. Educ. Psychol.* 25 (1) (2000) 54–67.
- [59] E.L. Deci, J.P. Connell, R.M. Ryan, Self-determination in a work organization, *J. Appl. Psychol.* 74 (4) (1989) 580.
- [60] S.S. Kim, C.-K. Lee, D.B. Klenosky, The influence of push and pull factors at Korean national parks, *Tourism Manag.* 24 (2) (2003) 169–180.
- [61] R.W. Rogers, Cognitive and psychological processes in fear appeals and attitude change: a revised theory of protection motivation, *Social psychophysiology: A sourcebook* (1983) 153–176.
- [62] J.-S. Horng, M.-L.M. Hu, C.-C.C. Teng, L. Lin, Energy saving and carbon reduction behaviors in tourism—a perception study of Asian visitors from a protection motivation theory perspective, *Asia Pac. J. Tourism Res.* 19 (6) (2014) 721–735.

- [63] S. Kim, S.-H. Jeong, Y. Hwang, Predictors of pro-environmental behaviors of American and Korean students: the application of the theory of reasoned action and protection motivation theory, *Sci. Commun.* 35 (2) (2013) 168–188.
- [64] S. Rousseau, N. Deschacht, Public awareness of nature and the environment during the COVID-19 crisis, *Environ. Resour. Econ.* (2020) 1–11.
- [65] V.L. Champion, C.S. Skinner, The health belief model, Health behavior and health education: Theory, research, and practice 4 (2008) 45–65.
- [66] A.J. Dillard, M.P. Couper, B.J. Zikmund-Fisher, Perceived risk of cancer and patient reports of participation in decisions about screening: the DECISIONS study, *Med. Decis. Making* 30 (5 suppl) (2010) 96–105.
- [67] M.J. Dutta, H. Feng, Health orientation and disease state as predictors of online health support group use, *Health Commun.* 22 (2) (2007) 181–189.
- [68] O. Kwon, L. Kahlor, Y. Kim, Are Seekers Also Doers? Linking Health Information Seeking and Health Behavioral Intentions from a Risk Perception Perspective, Annual meeting of the International Communication Association, 2011.
- [69] E.K. Yun, H.A. Park, Consumers' disease information-seeking behaviour on the Internet in Korea, *J. Clin. Nurs.* 19 (19-20) (2010) 2860–2868.
- [70] A.S. Ahadzadeh, S. Pahlevan Sharif, F.S. Ong, K.W. Khong, Integrating health belief model and technology acceptance model: an investigation of health-related internet use, *J. Med. Internet Res.* 17 (2) (2015) e45, <https://doi.org/10.2196/jmir.3564>.
- [71] K. Glanz, B.K. Rimer, K. Viswanath, Health Behavior and Health Education: Theory, Research, and Practice, John Wiley & Sons, 2008.
- [72] A. Zandifar, R. Badrfam, Iranian mental health during the COVID-19 epidemic, *Asian journal of psychiatry* 51 (2020) 101990.
- [73] P. Zhai, Y. Ding, X. Wu, J. Long, Y. Zhong, Y. Li, The epidemiology, diagnosis and treatment of COVID-19, *Int. J. Antimicrob. Agents* 105955 (2020), <https://doi.org/10.1016/j.ijantimicag.2020.105955>.
- [74] G. Zhu, J. Li, Z. Meng, Y. Yu, Y. Li, X. Tang, Y. Dong, G. Sun, R. Zhou, H. Wang, Learning from Large-Scale Wearable Device Data for Predicting Epidemics Trend of COVID-19, *Discrete Dynamics in Nature and Society*, 2020, 2020.
- [75] H.D. Dewhirst, Influence of perceived information-sharing norms on communication channel utilization, *Acad. Manag. J.* 14 (3) (1971) 305–315.
- [76] H.-P. Shih, Technology-push and communication-pull forces driving message-based coordination performance, *J. Strat. Inf. Syst.* 15 (2) (2006) 105–123, <https://doi.org/10.1016/j.jsis.2005.08.004>.
- [77] Z.F. Zamzuri, M. Manaf, Y. Yunus, A. Ahmad, Student perception on security requirement of e-learning services, *Procedia-Social and Behavioral Sciences* 90 (2013) 923–930.
- [78] P. McCole, E. Ramsey, J. Williams, Trust considerations on attitudes towards online purchasing: the moderating effect of privacy and security concerns, *J. Bus. Res.* 63 (9–10) (2010) 1018–1024.
- [79] R.I. Alsuwailam, Factors Affecting Faculty's Intent to Use E-Learning Systems at a University in the Kingdom of Saudi Arabia, 2018.
- [80] J. Hagen, E. Albrechtsen, S.O. Johnsen, The Long-term Effects of Information Security E-learning on Organizational Learning, *Information Management & Computer Security*, 2011.
- [81] D.C. Luminata, Information security in E-learning platforms, *Procedia-Social and Behavioral Sciences* 15 (2011) 2689–2693.
- [82] B. Mazumder, A. Moorthy, How does social distancing affect the spread of Covid-19 in the United States? *Chicago Fed Letter* 442 (2020).
- [83] D. Vlachopoulos, COVID-19: threat or opportunity for online education? *Higher Learning Research Communications* 10 (1) (2020) 2.
- [84] R.E. Hostler, V.Y. Yoon, Z. Guo, T. Guimaraes, G. Forgionne, Assessing the impact of recommender agents on on-line consumer unplanned purchase behavior, *Inf. Manag.* 48 (8) (2011) 336–343, <https://doi.org/10.1016/j.im.2011.08.002>.
- [85] M. Nilashi, D. Jannach, O.b. Ibrahim, M.D. Esfahani, H. Ahmadi, Recommendation quality, transparency, and website quality for trust-building in recommendation agents, *Electron. Commer. Res. Appl.* 19 (2016) 70–84, <https://doi.org/10.1016/j.elerap.2016.09.003>.
- [86] Y.-Y. Wang, A. Luse, A.M. Townsend, B.E. Mennecke, Understanding the moderating roles of types of recommender systems and products on customer behavioral intention to use recommender systems, *Inf. Syst. E Bus. Manag.* 13 (4) (2015) 769–799, <https://doi.org/10.1007/s10257-014-0269-9>.
- [87] D. Al-Fraihat, M. Joy, R.e. Masa'deh, J. Sinclair, Evaluating E-learning systems success: an empirical study, *Comput. Hum. Behav.* 102 (2020) 67–86, <https://doi.org/10.1016/j.chb.2019.08.004>.
- [88] S.S. Binyamin, M.J. Rutter, S. Smith, Extending the technology acceptance model to understand students' use of learning management systems in Saudi higher education, *International Journal of Emerging Technologies in Learning* 14 (3) (2019) 4–21, <https://doi.org/10.3991/ijet.v14i03.9732>.
- [89] R. Abumalloh, O. Ibrahim, M. Nilashi, Loyalty of Young Female Arabic Customers towards Recommendation Agents: A New Model for B2C E-Commerce, *Technology in Society*, 2020, p. 101253.
- [90] F. Faul, E. Erdfelder, A.-G. Lang, A. Buchner, G\* Power 3: a flexible statistical power analysis program for the social, behavioral, and biomedical sciences, *Behav. Res. Methods* 39 (2) (2007) 175–191.
- [91] J.F. Hair Jr., M. Sarstedt, L.M. Matthews, C.M. Ringle, Identifying and Treating Unobserved Heterogeneity with FIMIX-PLS: Part I–Method, *European Business Review*, 2016.
- [92] S. Asadi, M. Nilashi, A.R.C. Husin, E. Yadegaridehkordi, Customers perspectives on adoption of cloud computing in banking sector, *Inf. Technol. Manag.* 18 (4) (2017) 305–330.
- [93] S. Asadi, M. Nilashi, M. Safaei, R. Abdullah, F. Saeed, E. Yadegaridehkordi, S. Samad, Investigating factors influencing decision-makers' intention to adopt Green IT in Malaysian manufacturing industry, *Resour. Conserv. Recycl.* 148 (2019) 36–54.
- [94] C. Fornell, D.F. Larcker, Evaluating structural equation models with unobservable variables and measurement error, *J. Market. Res.* 18 (1) (1981) 39–50.
- [95] W.W. Chin, The partial least squares approach to structural equation modeling, *Modern methods for business research* 295 (2) (1998) 295–336.
- [96] J.-R. Fu, Understanding career commitment of IT professionals: perspectives of push–pull–mooring framework and investment model, *Int. J. Inf. Manag.* 31 (3) (2011) 279–293.
- [97] M.H. Zack, Electronic messaging and communication effectiveness in an ongoing work group, *Inf. Manag.* 26 (4) (1994) 231–241.
- [98] R.E. Kraut, L.A. Streeter, Coordination in software development, *Commun. ACM* 38 (3) (1995) 69–82.
- [99] Q. Liu, X. Zhang, S. Huang, L. Zhang, Y. Zhao, Exploring consumers' buying behavior in a large online promotion activity: the role of psychological distance and involvement, *Journal of theoretical and applied electronic commerce research* 15 (1) (2020), <https://doi.org/10.4067/s0718-18762020000100106>, 0–0.
- [100] I. Chakraborty, P. Maity, COVID-19 Outbreak: Migration, Effects on Society, *Global Environment and Prevention, Science of The Total Environment*, 2020, 138882.
- [101] A.D. Bryan, L.S. Aiken, S.G. West, Young women's condom use: the influence of acceptance of sexuality, control over the sexual encounter, and perceived susceptibility to common STDs, *Health Psychol.* 16 (5) (1997) 468.
- [102] J. Kim, H.-A. Park, Development of a health information technology acceptance model using consumers' health behavior intention, *J. Med. Internet Res.* 14 (5) (2012) e133.
- [103] N. Ferguson, A. Nicoll, B. Schwartz, SIP 5: social distancing during a pandemic. Not sexy, but sometimes effective: social distancing and non-pharmaceutical interventions, *Vaccine* 27 (45) (2009) 6383–6386, <https://doi.org/10.1016/j.vaccine.2009.08.010>.
- [104] M. Lallmahamood, An examination of Individual's perceived security and privacy of the internet in Malaysia and the influence of this on their intention to use E-commerce: using an extension of the technology acceptance model, *J. Internet Bank. Commer.* 12 (3) (1970) 1–26.